



# GTW 3-WAY CONTROL VALVE

**SIZES 1/2" – 12"**  
**ANSI CLASS 125/250, 150/300**

- **Rigid Port Guiding** dampens vibration and ensures proper seating
- **High Capacity Body Designs** means valve body flow areas are 140% of normal valve, reducing velocities and pressure loss
- **Balanced Plug Design** of DV provides gradual, stable transition
- **316 SS Valve Plugs & Seat Rings** for corrosion resistance
- **Mixing or Diverting** in Cast Iron, Carbon Steel or Stainless Steel to suit your application
- **Spring Loaded V-ring Packing** is self adjusting

## GTW THREE WAY CONTROL VALVE

### APPLICATION DATA

- Process control systems for food, pulp and paper, chemical, petrochemical & other industries
- HVAC systems
- Feed water and fuel system controls in boiler rooms
- Packaged systems (OEM) such as heat exchangers, water purification systems & vaporizer, metal cleaning and plating
- Especially designed for mix or diverting of clean, dirty, viscous and corrosive liquids, gasses and steam

### OPTIONS

- 40 and 85 sq. in. Reverse and Direct Actuators
- Soft Seat
- Positioners and Other Accessories
- Alternate Packing for Severe Service
- Graphite or High Temperature Packing

**APPLICABLE CODES** See Reference Section on page 195

THREE WAY

**CAST IRON**  
**A126 Class B**

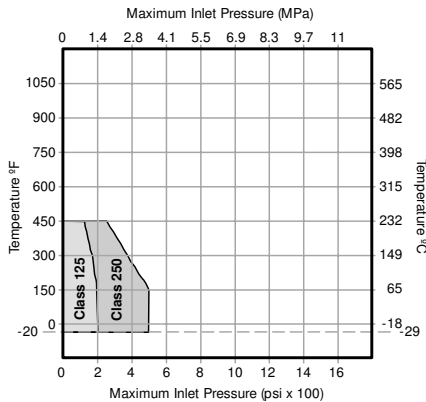

**CARBON STEEL**  
**A216 Gr. WCB - Standard Class**

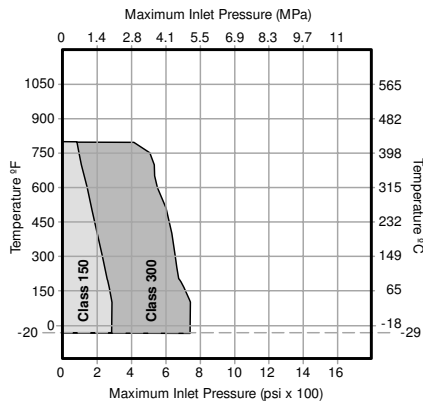

**316 STAINLESS STEEL CF8M**  
**Class A - Standard**

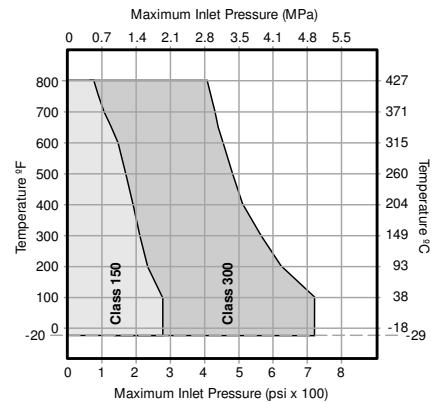

### MAXIMUM RATED FLOW COEFFICIENTS Cv AND STROKE inches (mm)

		VALVE SIZE											
		1/2	3/4	1	1 1/2	2	2 1/2	3	4	6	8	10	12
		(15)	(20)	(25)	(40)	(50)	(65)	(80)	(100)	(150)	(200)	(250)	(300)
MX		5	7	12	28	50	70	116	158	352	475	739	1070
DV		5	7	12	28	52	76	108	160	365	475	795	1078
Stroke		1 5/2	1 5/2	1 1/6	1 5/6	1 1/6	1 3/6	1 3/6	1 3/6	2 3/6	2 1/2	3	3 1/2
		(12)	(12)	(17.5)	(23.8)	(26.6)	(29.8)	(34.5)	(44.1)	(59.5)	(62.7)	(80)	(87.7)

# GTW PRINCIPLE OF OPERATION

The Three Way Globe Valve design has been successfully applied for over 50 years in chemical, refining, power, paper, and H.V.A.C. industries worldwide. They are designed for mixing or diverting of clean, dirty, viscous and corrosive liquids, high and low pressure steam, and clean, dirty and corrosive gases.

## MIXING SERVICE (Type MX)

The inner valves in type MX seat inside the two seat rings (see illustration A). When these valves are used for mixing service, the forces developed by the two inlet flows oppose each other, creating little, if any, unbalance. Thus, the actuator can control the flow efficiently, with very little power lost in overcoming dynamic unbalance.

The Type MX valve is also used for diverting service, generally restricted to the smaller sizes (see illustration B).

## DIVERTING SERVICE (Type DV)

In contrast to the MX control valve, the inner valve in the type DV seats outside the two seat rings (see illustration C). The flow enters between the two seats and the pressure tends to move the inner valve away from the seats, adding to the stability of operation. Therefore, the Type DV is preferred for diverting service in larger valve sizes and at higher pressure.

## FLOW CONFIGURATIONS

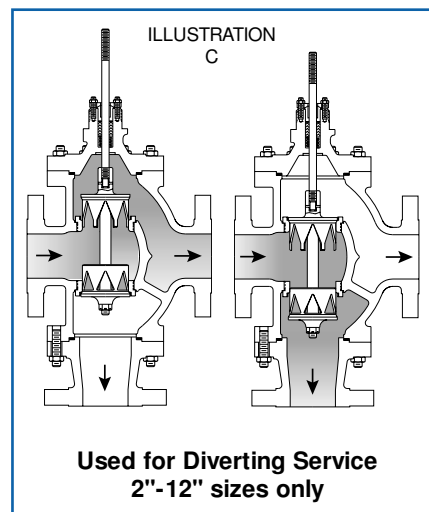
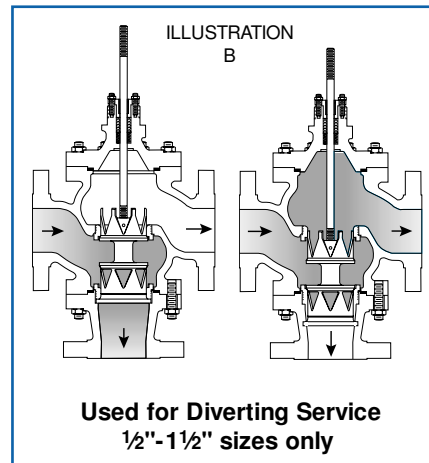
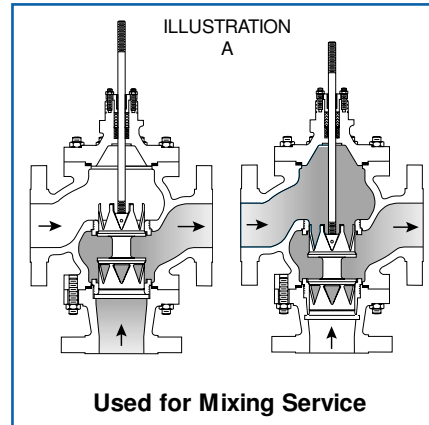

**Note:** When selecting a direct acting actuator, plug is up on air loss. When selecting a reverse acting actuator, plug is down on air loss.

## MIXING

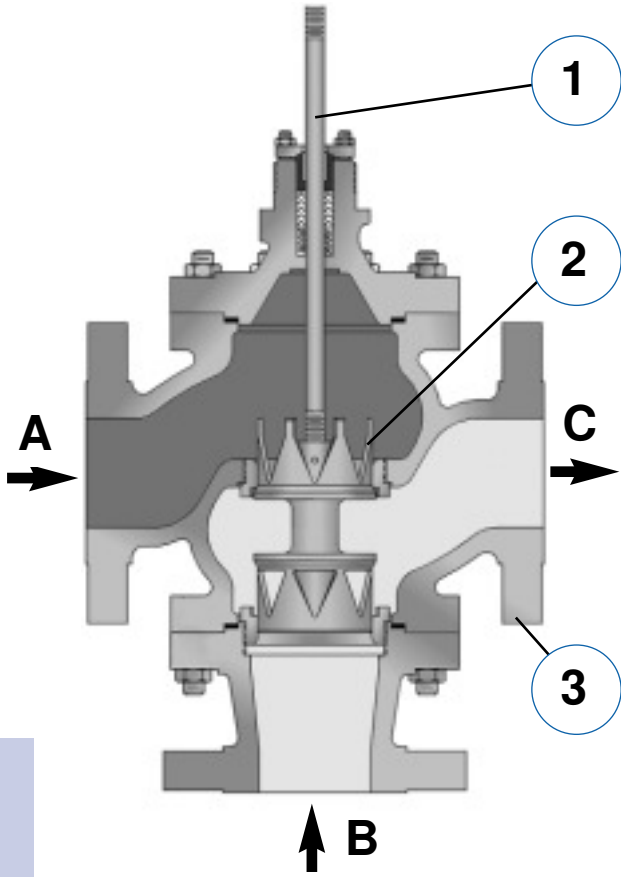

## DIVERTING

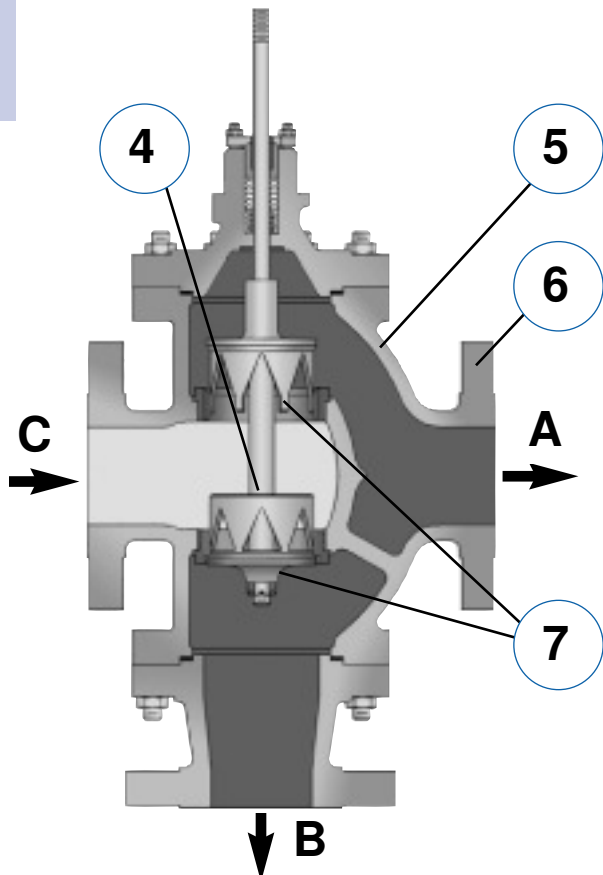

THREE WAY

# Solution-Engineered Features for Demanding Applications

## 1. Stem Packing

### Teflon® V-Ring Packing-Standard (T)

Live-loaded and pressure-assisted v-rings provide a tight self-adjusting stem seal for process applications from 32-450 °F (0-232 °C).

### Braided Teflon®/Graphite (B)

Graphite impregnated PTFE split rings provide 500 °F service temperatures, less stem hysteresis, more “dirt-tolerance”, better “memory” and stem sealing than pure PTFE rings.

### Laminated Graphite (L)

Precision-cut, laminated graphite rings suitable for process temperatures to 800 °F (427 °C).

## 2. Corrosion-Resistant Trim

Valve plugs and seat rings are manufactured from 316 stainless steel providing corrosion resistance and ease of long term maintenance.

## 3. Size & End Connections

### Mixing (Type MX)

The GTW, Type MX is available in ½" - 12" (15-300mm) size, in cast iron and carbon steel bodies (other materials on application). NPT screwed end connections are available in ½" - 2" size. Ring type joint flanges available on request.

### Diverting (Type DV)

The GTW, Type DV is available in the same materials as the Type MX in sizes ½" - 12" (15-300mm) sizes.

## 4. Balanced Plug Design-Diverting

V-notch flow ports and balanced plug design provide stable port switching by preventing valve slamming and pipeline water hammer. Flow entering the valve between the flow ports acts to push both plugs away from the seats providing a stable transition when switching ports.

## 5. Rigid Port Guiding

Port Guiding provides rigid support and guiding of the plug directly at the point of maximum fluid velocity and pressure drop. This type of plug guiding provides maximum resistance against plug vibration and eliminates plug mis-alignment for proper seating.

## 6. High Capacity Body Designs

Body configurations incorporate flow areas 140% of normal valve size. These enlarged flow areas minimize fluid velocities and turbulence, maximizing body/trim life and valve efficiency.

## 7. Stable and True Linear Proportioning

Engineered V-notch flow ports provide true linear proportioning in mixing applications and gradual flow reduction in diverting applications.

# GTW 3 WAY VALVE ACTUATOR SIZING INFORMATION

Based on your valve size and service please complete the appropriate questionnaire section below. We require this information to size the smallest actuator possible for your application. We have requested the data this way because the ports may be at different pressures when one or the other port is closed. It is very important that

you advise the correct outlet pressures so the actuator is not grossly oversized. If the customer does not have any down stream pressure when the valve is closed the actuator will be extremely large as the valve becomes an unbalanced design.

## 1/2" through 2" Diverting Service

Upon air failure close Port A \_\_\_\_\_(direct) or Port B \_\_\_\_\_(reverse)

Valve Size \_\_\_\_\_

Type of packing \_\_\_\_\_

Shutoff Class \_\_\_\_\_

P1C - Inlet valve pressure \_\_\_\_\_

Port A closed

P2A - Outlet valve pressure on Port A \_\_\_\_\_

P2B - Outlet valve pressure on Port B \_\_\_\_\_

Port B closed

P2A - Outlet valve pressure on Port A \_\_\_\_\_

P2B - Outlet valve pressure on Port B \_\_\_\_\_

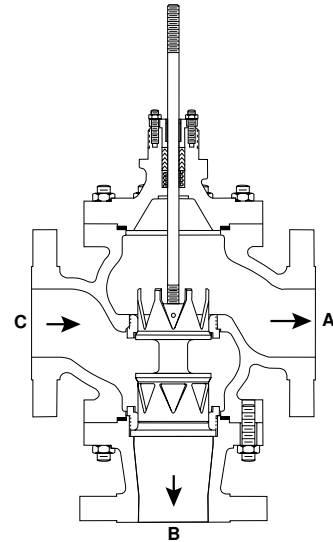

## 2½" through 12" Diverting Service

Upon air failure close Port A \_\_\_\_\_(reverse) or Port B \_\_\_\_\_(direct)

Valve Size \_\_\_\_\_

Type of packing \_\_\_\_\_

Shutoff Class \_\_\_\_\_

P1C - Inlet valve pressure \_\_\_\_\_

Port A closed

P2A - Outlet valve pressure on Port A \_\_\_\_\_

P2B - Outlet valve pressure on Port B \_\_\_\_\_

Port B closed

P2A - Outlet valve pressure on Port A \_\_\_\_\_

P2B - Outlet valve pressure on Port B \_\_\_\_\_

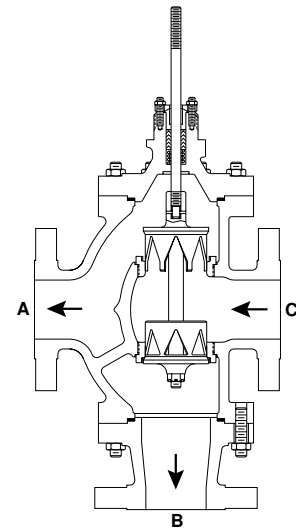

## 1/2" through 12" Mixing Service

Upon air failure close Port A \_\_\_\_\_(direct) or Port B \_\_\_\_\_(reverse)

Valve Size \_\_\_\_\_

Type of packing \_\_\_\_\_

Shutoff Class \_\_\_\_\_

P2C - Outlet valve pressure \_\_\_\_\_

Port A closed

P1A - Inlet valve pressure on Port A \_\_\_\_\_

P1B - Inlet valve pressure on Port B \_\_\_\_\_

Port B closed

P1A - Inlet valve pressure on Port A \_\_\_\_\_

P1B - Inlet valve pressure on Port B \_\_\_\_\_

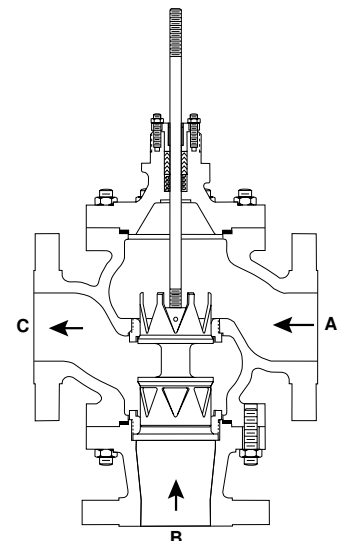

THREE WAY

# GTW ACTUATOR CHARTS

THREE WAY

Actuator	Yoke Used	Valve Size	Valve Stroke	Spring Part Number	Max Comp	Max Spring Force	Up Seating Spring Force (0 psig Air)	Max Upper Bench	Max Lower Bench	Down Seating Force (60 psig Air)
ACT,DL-40-D-C-B1	C	0.5/0.75	0.469	KM1183819	1.95	848.25	644.2	21.2	16.1	1551.7
		1	0.688				549.0		13.7	
		1.5	0.938				440.2		11.0	
		2	1.06				387.2		9.7	
		2.5	1.19				330.6		8.3	
		3	1.38				248.0		6.2	
		4	1.75				87.0		2.2	
ACT,DL-85-D-E-C1	E	0.5/0.75	0.469	KM1193668	2.03	1835	1413.9	21.6	16.6	564.0
		1	0.688				1216.8		14.3	
		1.5	0.938				991.8		11.7	
		2	1.06				882.0		10.4	
		2.5	1.19				765.0		9.0	
		3	1.38				594.0		7.0	
		4	1.75				261.0		3.1	
ACT,DL-85-D-E-C6	E	0.5/0.75	0.469	KM1193673	2.75	1650	1368.6	19.4	16.1	750.0
		1	0.688				1237.2		14.6	
		1.5	0.938				1087.2		12.8	
		2	1.06				1014.0		11.9	
		2.5	1.19				936.0		11.0	
		3	1.38				822.0		9.7	
		4	1.75				600.0		7.1	
ACT,DL-85-D-E-C7 <sup>1</sup>	E	0.5/0.75	0.469	KM1193674	8.25	4001.3	3773.8	47.1	44.4	1098.8
		1	0.688				3667.6		43.1	
		1.5	0.938				3546.3		41.7	
		2	1.06				3487.2		41.0	
		2.5	1.19				3424.1		40.3	
		3	1.38				3332.0		39.2	
		4	1.75				3152.5		37.1	
ACT,DL-40-R-C-B1	C	0.5/0.75	0.469	KM1183819	1.95	848.25	644.2	21.2	16.1	1551.7
		1	0.688				549.0		13.7	
		1.5	0.938				440.2		11.0	
		2	1.06				387.2		9.7	
		2.5	1.19				330.6		8.3	
		3	1.38				248.0		6.2	
		4	1.75				87.0		2.2	
ACT,DL-40-R-C-B7 <sup>1</sup>	C	0.5/0.75	0.469	KM1179418	4.25	2265.25	2015.3	56.6	50.4	134.8
		1	0.688				1898.5		47.5	
		1.5	0.938				1765.3		44.1	
		2	1.06				1700.3		42.5	
		2.5	1.19				1631.0		40.8	
		3	1.38				1529.7		38.2	
		4	1.75				1332.5		33.3	
ACT,DL-85-R-E-C2	E	0.5/0.75	0.469	KM1193669	1.51	1900.0	1313.7	22.4	15.5	3200.0
		1	0.688				1040.0		12.2	
		1.5	0.938				727.5		8.6	
		2	1.06				575.0		6.8	
		2.5	1.19				412.5		4.9	
		3	1.38				175.0		2.1	
		4	1.75				-287.5		-3.4	
ACT,DL-85-R-E-C7 <sup>1</sup>	E	0.5/0.75	0.469	KM1193674	8.25	4001.3	3773.8	47.1	44.4	1098.8
		1	0.688				3667.6		43.1	
		1.5	0.938				3546.3		41.7	
		2	1.06				3487.2		41.0	
		2.5	1.19				3424.1		40.3	
		3	1.38				3332.0		39.2	
		4	1.75				3152.5		37.1	

1. Spring B7, C7, D4 and F7 are not available in direct



# GTW WATER CAPACITY TABLE

(Modified Equal Percent Contour Plug) (M3/Hr.)

THREE WAY

Pressure (M <sub>3</sub> /hr)		Valve Size and Type																							
		1/2		3/4		1		1.5		2		2.5		3		4		6		8		10		12	
P1	P2																								
0.7	0.5	2	3	5	11	19	20	27	29	45	42	61	62	136	141	184	286	307	414	417					
	0.2	3	4	7	17	31	32	43	46	71	66	97	98	215	223	290	452	486	654	659					
1	0.7	2	3	6	13	24	25	33	36	55	51	75	76	167	173	225	350	377	507	511					
	0.5	3	4	7	17	31	32	43	46	71	66	97	98	215	223	290	452	486	654	659					
	.2	4	5	9	22	39	40	54	59	90	84	122	124	272	282	367	572	615	828	834					
1.5	1	3	4	7	17	31	32	43	46	71	66	97	98	215	223	290	452	486	654	659					
	0.7	4	5	9	22	39	40	54	59	90	84	122	124	272	282	367	572	615	828	834					
	.2	5	7	12	28	49	51	69	75	114	106	156	158	347	360	468	729	784	1055	1063					
2	1.5	3	4	7	17	31	32	43	46	71	66	97	98	215	223	290	452	486	654	659					
	1	4	6	10	24	43	45	61	66	100	93	137	138	304	316	411	639	687	925	932					
	.3	6	8	14	32	56	59	79	86	131	122	178	180	397	412	536	833	896	1206	1215					
3	2	4	6	10	24	43	45	61	66	100	93	137	138	304	316	411	639	687	925	932					
	1	6	9	15	34	61	64	86	93	142	132	193	196	430	446	581	904	972	1309	1318					
	.5	7	10	16	38	68	71	96	104	159	148	216	219	481	499	649	1010	1087	1463	1474					
3.5	3	3	4	7	17	31	32	43	46	71	66	97	98	215	223	290	452	486	654	659					
	2	5	7	13	30	53	55	74	80	123	114	167	169	373	387	503	783	842	1133	1142					
	1	7	10	16	38	68	71	96	104	159	148	216	219	481	499	649	1010	1087	1463	1474					
	.5	7	10	18	42	75	78	105	114	174	162	237	240	527	547	711	1107	1191	1603	1615					
4	3	4	6	10	24	43	45	61	66	100	93	137	138	304	316	411	639	687	925	932					
	2	6	9	15	34	61	64	86	93	142	132	193	196	430	446	581	904	972	1309	1318					
	1	7	10	18	42	75	78	105	114	174	162	237	240	527	547	711	1107	1191	1603	1615					
	.6	8	11	19	45	80	83	112	121	185	172	252	255	561	582	757	1178	1268	1706	1719					
5	4	4	6	10	24	43	45	61	66	100	93	137	138	304	316	411	639	687	925	932					
	3	6	9	15	34	61	64	86	93	142	132	193	196	430	446	581	904	972	1309	1318					
	2	7	10	18	42	75	78	105	114	174	162	237	240	527	547	711	1107	1191	1603	1615					
	.8	9	12	21	50	89	92	124	135	206	191	280	284	624	647	842	1310	1409	1896	1910					
6	5	4	6	10	24	43	45	61	66	100	93	137	138	304	316	411	639	687	925	932					
	3	7	10	18	42	75	78	105	114	174	162	237	240	527	547	711	1107	1191	1603	1615					
	1	10	14	23	54	97	101	135	147	224	209	306	309	681	706	919	1429	1537	2069	2085					
8	6	6	9	15	34	61	64	86	93	142	132	193	196	430	446	581	904	972	1309	1318					
	3	10	14	23	54	97	101	135	147	224	209	306	309	681	706	919	1429	1537	2069	2085					
	1.1	11	16	27	64	114	118	159	173	264	245	359	363	800	829	1079	1679	1806	2431	2449					
10	8	6	9	15	34	61	64	86	93	142	132	193	196	430	446	581	904	972	1309	1318					
	5	10	14	23	54	97	101	135	147	224	209	306	309	681	706	919	1429	1537	2069	2085					
	1.4	13	18	30	71	127	132	178	193	294	274	401	406	893	926	1205	1874	2016	2714	2734					
12	10	6	9	15	34	61	64	86	93	142	132	193	196	430	446	581	904	972	1309	1318					
	7	10	14	23	54	97	101	135	147	224	209	306	309	681	706	919	1429	1537	2069	2085					
	5	11	16	27	64	114	119	160	174	265	247	361	366	805	835	1087	1691	1819	2448	2466					
	1.7	14	19	33	78	139	144	194	211	322	300	439	444	977	1013	1318	2051	2206	2970	2992					
14	10	9	12	21	48	86	90	121	131	201	187	273	277	609	631	822	1278	1375	1851	1864					
	7	11	16	27	64	114	119	160	174	265	247	361	366	805	835	1087	1691	1819	2448	2466					
	2	15	21	36	84	150	156	210	228	347	324	473	479	1054	1093	1423	2214	2382	3205	3229					
15	12	7	10	18	42	75	78	105	114	174	162	237	240	527	547	711	1107	1191	1603	1615					
	7	12	17	29	68	122	127	171	186	284	264	386	391	861	893	1162	1808	1945	2617	2637					
	2	16	22	37	87	156	162	218	237	362	337	493	499	1098	1138	1481	2304	2479	3336	3361					
17	14	7	10	18	42	75	78	105	114	174	162	237	240	527	547	711	1107	1191	1603	1615					
	10	11	16	27	64	114	119	160	174	265	247	361	366	805	835	1087	1691	1819	2448	2466					
	5	15	21	36	84	150	156	210	228	347	324	473	479	1054	1093	1423	2214	2382	3205	3229					
	2.4	17	23	40	93	165	172	231	251	383	357	522	529	1163	1206	1570	2442	2627	3536	3562					
20	15	10	14	23	54	97	101	135	147	224	209	306	309	681	706	919	1429	1537	2069	2085					
	10	14	19	33	77	137	142	191	208	317	295	432	438	963	998	1299	2021	2174	2926	2948					
	2.7	18	25	43	101	180	187	252	273	417	388	568	575	1266	1313	1709	2658	2860	3849	3877					
27	20	11	16	27	64	114	119	160	174	265	247	361	366	805	835	1087	1691	1819	2448	2466					
	3.5	15	21	36	84	150	156	210	228	347	324	473	479	1054	1093	1423	2214	2382	3205	3229					

- It is recommended to keep valve outlet velocity below 30,000 ft./min.
- Capacities based on maximum Cv.

# GTW THREE WAY VALVES

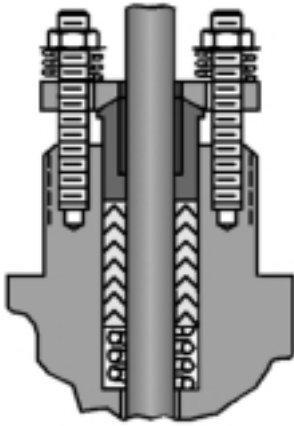

(T) Teflon Chevron

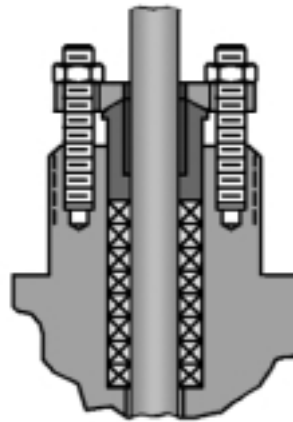

(B) BTG

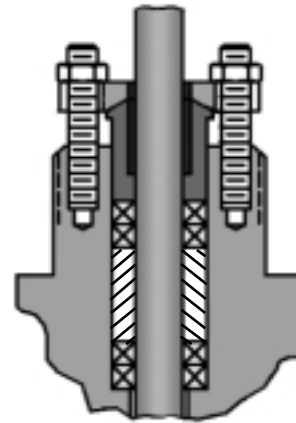

(L) Laminated Graphite

THREE WAY

## Sizing Coefficients

TYPE	$F_L$	$K_c$	$X_T$
Mixing - MX	.95	.75	.76
Diverting - DV	.93	.71	.73



# GTW Body Dimensions

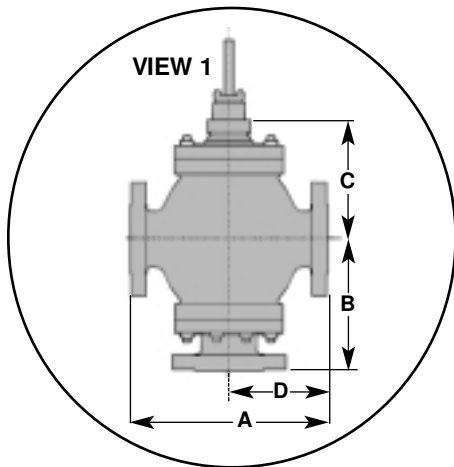

Valve Sizes - Flanged Ends  
 Diverting ½" - 1½"  
 Mixing ½" - 12"

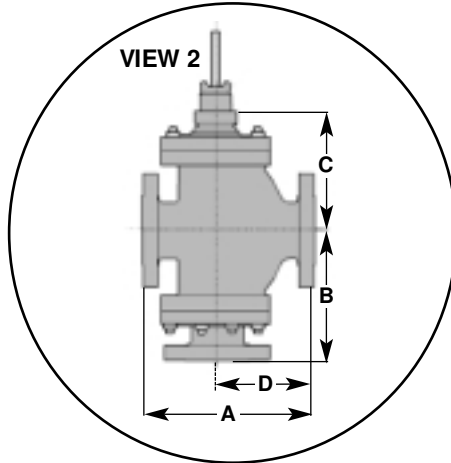

Valve Sizes - Flanged Ends  
 Diverting 2" - 12"

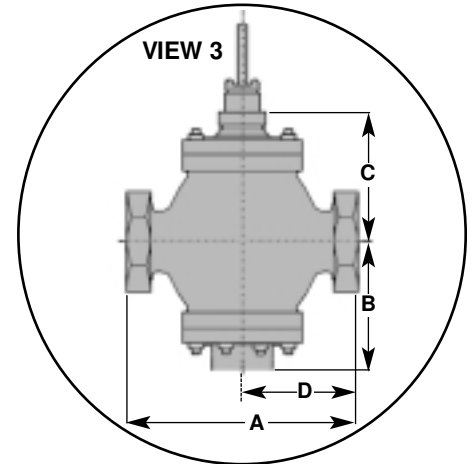

Valve Sizes - Threaded Ends  
 Diverting ½" - 1½"  
 Mixing ½" - 2"

BODY DIMENSIONS inches (mm),  
 WEIGHTS pounds (kg) AND VOLUME cu.ft. (m³)

VALVE SIZE	Threaded 250 / 300												WEIGHT	VOLUME
	A		B		C		D		D		D			
	Diverting	Mixing	Diverting	Mixing	Diverting	Mixing	Diverting	Mixing	Diverting	Mixing	Diverting	Mixing		
0.5 (15)	5 1/16 (144.5)	5 1/16 (144.5)	3 3/8 (92.1)	3 3/8 (92.1)	4 1/2 (117.5)	4 1/2 (117.5)	*	*	45 (20)	1 (.03)				
.75 (20)	5 1/16 (144.5)	5 1/16 (144.5)	3 3/8 (92.1)	3 3/8 (92.1)	4 1/2 (117.5)	4 1/2 (117.5)	3 1/16 (77.8)	3 1/16 (77.8)	45 (20)	1 (.03)				
1 (25)	6 3/8 (157.2)	6 3/8 (157.2)	4 7/8 (112.7)	4 7/8 (112.7)	5 7/8 (138.1)	5 7/8 (138.1)	3 3/4 (82.6)	3 3/4 (82.6)	6 (28)	1 (.03)				
1.5 (40)	7 3/4 (196.9)	7 3/4 (196.9)	5 1/2 (139.7)	5 1/2 (139.7)	6 1/2 (158.8)	6 1/2 (158.8)	4 1/2 (111.1)	4 1/2 (111.1)	72 (33)	2 (.06)				
2 (50)	—	9 3/4 (233.4)	—	6 1/4 (158.8)	—	6 1/4 (174.6)	—	5 (127)	94 (43)	2 (.06)				

\*Consult Factory

NOTE 1. 0.5" CI 250 Class is 3 3/8" and Steel 300 Class is 4".

Numbers after dimensions refer to diagram view above.

THREE WAY

VALVE SIZE	ANSI Flange 125 / 150												ANSI Flange 250 300												WEIGHT	VOLUME
	A		B		C		D		A		B		C		D											
	Diverting	Mixing	Diverting	Mixing	Diverting	Mixing	Diverting	Mixing	Diverting	Mixing	Diverting	Mixing	Diverting	Mixing	Diverting	Mixing										
0.5 (15)	7 1/2 (190.5)	7 1/2 (190.5)	5 1/8 (141.3)	5 1/8 (141.3)	4 1/2 (117.5)	4 1/2 (117.5)	3 3/8 (98.4)	3 3/8 (98.4)	7 1/4 (184.2)	7 1/4 (184.2)	5 11/16 (144.5)	5 11/16 (144.5)	4 5/8 (117.5)	4 5/8 (117.5)	Note 1	Note 1	45 (20)	1 (.03)								
.75 (20)	7 1/4 (184.2)	7 1/4 (184.2)	5 1/8 (141.3)	5 1/8 (141.3)	4 1/2 (117.5)	4 1/2 (117.5)	3 3/8 (98.4)	3 3/8 (98.4)	7 3/8 (193.7)	7 3/8 (193.7)	5 1/4 (146.1)	5 1/4 (146.1)	4 5/8 (117.5)	4 5/8 (117.5)	4 1/2 (103.2)	4 1/2 (103.2)	45 (20)	1 (.03)								
1 (25)	7 1/4 (184.2)	7 1/4 (184.2)	6 3/8 (157.2)	6 3/8 (157.2)	5 1/8 (138.1)	5 1/8 (138.1)	3 3/4 (95.3)	3 3/4 (95.3)	7 3/4 (196.9)	7 3/4 (196.9)	6 1/8 (163.5)	6 1/8 (163.5)	5 1/8 (138.1)	5 1/8 (138.1)	4 (101.6)	4 (101.6)	6 (28)	1 (.03)								
1.5 (40)	8 3/4 (222.3)	8 3/4 (222.3)	7 1/8 (188.9)	7 1/8 (188.9)	6 1/4 (158.8)	6 1/4 (158.8)	4 1/2 (112.7)	4 1/2 (112.7)	9 1/4 (235)	9 1/4 (235)	7 11/16 (195.3)	7 11/16 (195.3)	6 1/4 (158.8)	6 1/4 (158.8)	4 1/8 (119.1)	4 1/8 (119.1)	72 (33)	2 (.06)								
2 (50)	10 (254.0)	10 (254.0)	7 13/16 (198.4)	7 13/16 (198.4)	6 3/4 (174.6)	6 3/4 (174.6)	5 1/2 (138.1)	5 1/2 (138.1)	10 1/2 (266.7)	10 1/2 (266.7)	8 1/8 (204.8)	8 1/8 (204.8)	6 3/8 (174.6)	6 3/8 (174.6)	5 11/16 (144.5)	5 11/16 (144.5)	94 (43)	2 (.06)								
2.5 (65)	10 7/8 (276.2)	10 7/8 (276.2)	8 1/4 (222.3)	8 1/4 (222.3)	7 1/2 (194.5)	7 1/2 (194.5)	6 1/2 (155.6)	6 1/2 (155.6)	11 1/2 (292.1)	11 1/2 (292.1)	9 1/8 (230.2)	9 1/8 (230.2)	7 1/2 (194.5)	7 1/2 (194.5)	6 1/8 (163.5)	6 1/8 (163.5)	105 (48)	3 (.08)								
3 (80)	11 1/4 (298.5)	11 1/4 (298.5)	8 13/32 (243.7)	8 13/32 (243.7)	7 1/2 (194.5)	7 1/2 (194.5)	6 1/2 (155.6)	6 1/2 (155.6)	12 1/2 (317.5)	12 1/2 (317.5)	9 3/16 (231.5)	9 3/16 (231.5)	8 1/8 (217.5)	8 1/8 (217.5)	7 1/8 (182.6)	7 1/8 (182.6)	160 (73)	3 (.08)								
4 (100)	13 1/8 (352.4)	13 1/8 (352.4)	11 1/8 (282.6)	11 1/8 (282.6)	9 1/2 (250.8)	9 1/2 (250.8)	8 1/2 (227.0)	8 1/2 (227.0)	14 1/2 (368.3)	14 1/2 (368.3)	11 1/2 (290.5)	11 1/2 (290.5)	10 1/2 (266.7)	10 1/2 (266.7)	8 1/8 (214.3)	8 1/8 (214.3)	193 (88)	5 (.14)								
6 (150)	17 1/2 (450.9)	17 1/2 (450.9)	14 1/2 (371.5)	14 1/2 (371.5)	11 1/2 (300.0)	11 1/2 (300.0)	10 1/2 (265.1)	10 1/2 (265.1)	18 1/2 (473.1)	18 1/2 (473.1)	15 1/8 (382.6)	15 1/8 (382.6)	12 1/8 (319.1)	12 1/8 (319.1)	10 7/8 (276.2)	10 7/8 (276.2)	455 (206)	8 (.23)								
8 (200)	21 3/8 (542.9)	21 3/8 (542.9)	16 23/32 (429.4)	16 23/32 (429.4)	13 1/2 (346.6)	13 1/2 (346.6)	11 1/2 (300.0)	11 1/2 (300.0)	22 3/8 (568.3)	22 3/8 (568.3)	17 1/2 (442.1)	17 1/2 (442.1)	15 1/8 (386.6)	15 1/8 (386.6)	13 1/8 (335.0)	13 1/8 (335.0)	635 (288)	13 (.37)								
10 (250)	25 1/2 (647.7)	25 1/2 (647.7)	19 23/32 (500.9)	19 23/32 (500.9)	15 1/2 (431.8)	15 1/2 (431.8)	13 1/2 (339.7)	13 1/2 (339.7)	26 3/8 (682.6)	26 3/8 (682.6)	20 3/8 (517.5)	20 3/8 (517.5)	18 1/2 (462.8)	18 1/2 (462.8)	16 1/8 (411.2)	16 1/8 (411.2)	1050 (476)	21 (.59)								
12 (300)	*	29 3/8 (755.7)	*	19 1/8 (503.2)	*	18 1/8 (466.7)	*	14 1/2 (377.8)	*	31 1/4 (793.8)	*	20 3/8 (522.3)	*	18 1/8 (466.7)	*	15 1/2 (396.9)	1690 (767)	30 (.85)								

# GTW ACTUATOR

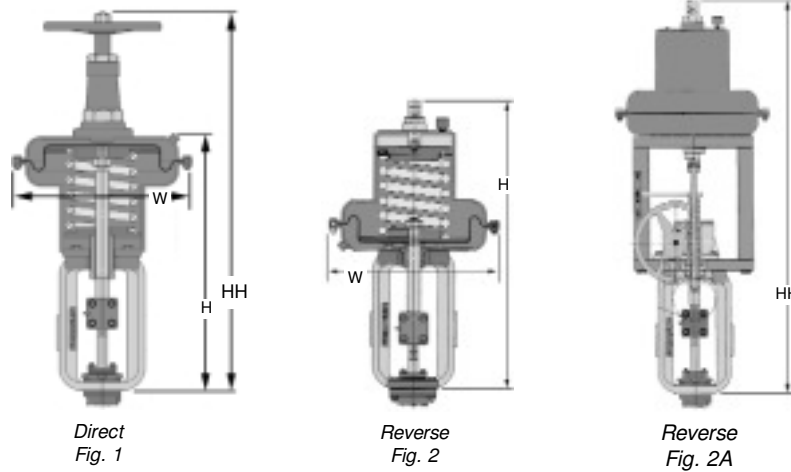

## ACTUATOR DIMENSIONS inches (mm) AND WEIGHTS pounds (kg)

MODEL	DIRECT		REVERSE		W	WGT.	
	H	HH	H	HH <sup>1</sup>		DIRECT	REVERSE
40	19.5 (495)	32.7 (831)	25.8 (655)	39.8 (1011)	10.1 (257)	37 (817)	54 (25)
85	20.9 (531)	41.7 (1059)	38.4 (975)	57.4 (1458)	14.8 (375)	84 (38)	125 (57)

1. See Fig. 2A

# GTW SPECIFICATIONS

Description		Material Specification	Temp. Range
<b>Trim Modules</b>			
1	Plug	316 Stainless Steel ASTM A351 Grade CF8M	-20 — 800°F (29°C—427°C)
2	Seat Rings	316 Stainless Steel ASTM A351 Grade CF8M	-20 — 800°F (29°C—427°C)
3	Pin	302 Stainless Steel	-20 — 800°F (29°C—427°C)
4	Stem	316 Stainless Steel	-20 — 800°F (29°C—427°C)
<b>Packing Module</b>			
5	Spring (V-Ring Packing)	316 Stainless Steel	-20 — 800°F (29°C—427°C)
6	Packing Set (B)	Braided Teflon Graphite	-40 — 500°F (-40°C—232°C)
6	Packing Set (T)	Teflon-Chevron	-40 — 450°F (-40°C—232°C)
7	Packing Set (L)	Laminated Graphite	-425 — 800°F (-29°C—427°C)
9	Packing Follower	316 Stainless Steel	-20 — 800°F (-29°C—427°C)
10	Packing Flange	Cadmium Plated Steel	-20 — 800°F (-29°C—427°C)
11	Hex Nut	316 Stainless Steel	-20 — 800°F (-29°C—427°C)
12	Studs	316 Stainless Steel	-20 — 800°F (-29°C—427°C)
<b>Body/Bonnet Materials</b>			
13	Nut	ASTM A-194 Gr.2H	-20 — 800°F (29°C—427°C)
13	Nut	ASTM A-194 Gr.7	-20 — 800°F (29°C—427°C)
14	Stud	ASTM A-193 Gr.B7	-20 — 800°F (29°C—427°C)
14	Stud	ASTM A-193 B 16	-20 — 800°F (-29°C—427°C)
15	Gasket	Nitrile Rubber Bonded	32 — 450°F (0°C—230°C)
15	Gasket	PTFE	-32 — 450°F (-35°C—230°C)
15	Gasket	Grafoil®	-120 — 800°F (-195°C—427°C)
16	Body/Bonnet/Lower Adapter	Cast Iron ASTM A-126 Class B	-20 — 450°F (-29°C—232°C)
16	Body/Bonnet/Lower Adapter	*Steel ASTM A-216 Gr.WCB	-20 — 800°F (-29°C—427°C)
16	Body/Bonnet/Lower Adapter	*316 Stainless Steel ASTM A-351 Gr.CF8M	-20 — 800°F (-29°C—427°C)

\* Consult ANSI B16.1 (cast iron) or ANSI B16.34 (other body materials) for pressure/temperature limits of body/bonnet assembly.

# GTW ORDERING CODE

Class	Size	Ends	Body Material	Packing Bonnet Type	Gasket	Valve Function	Actuator Size & Action	Actuator Yoke	Actuator Spring	Manual Override	Number of Accessories	European Approval			
K	W	H	B	2	T	1	M	8	E	C	2	N	0	C	E
1	2	3	4	5	6	7	8	9	10	11	12	13	14	15	16

<b>Class</b> - Position 1 & 2 KW = Globe 3-way
<b>Size</b> - Position 3 A = ½" B = ¾" C = 1" E = 1½" F = 2" G = 2½" H = 3" J = 4" K = 6" L = 8" M = 10" N = 12"
<b>Ends</b> - Position 4 A = Flg. 125/150 B = Flg. 250/300 C = NPT
<b>Body Mat'l</b> - Position 5 1 = Cast Iron 2 = Carbon Steel 3 = Stainless Steel

<b>Packing/Std. Bonnet</b> - Position 6 T = Teflon Chevron B = Braided Teflon Graphite L = Laminated Graphite
<b>Gasket</b> - Position 7 1 = Nitrile rubber bonded 2 = PTFE 3 = Grafoil X = Other
<b>Valve Function</b> - Position 8 M = Mixing D = Diverting
<b>Actuator Size &amp; Action</b> - Position 9 4 = 40 Direct 5 = 40 Reverse 8 = 85 Direct 9 = 85 Reverse N = No Actuator X = Other
<b>Actuator Yoke</b> - Position 10 C = 2.31 Dia Hub (40 Act) E = 2.31 Dia Hub (85 Act) N = No Actuator

<b>Actuator Spring</b> - Position 11&12		
<b>Order Code</b>	<b>Spring Rate</b>	<b>Max. Comp.</b>
Used w/size 40 actuator		
B1 =	435	1.95
B2 =	590	1.52
B3 =	875	1.95
B4 =	1180	1.52
B5 =	1850	0.92
B6 =	300	2.75
B7 <sup>1</sup> =	533	4.25
Used w/size 85 actuator		
C1 =	900	2.04
C2 =	1250	1.52
C3 =	1850	2.04
C4 =	2500	1.52
C5 =	3867	0.92
C6 =	600	2.75
C7 <sup>1</sup> =	485	8.25
NN = No Actuator/Bare Stem XX = Other		
<b>Manual Override</b> - Position 13 N = None M = Manual Override (Handwheel)		
<b>Accessories</b> - Position 14 0 = No Accessories Mounted 1-8 = Actual Number of Accessories Mounted <sup>2</sup>		
<b>European Approval</b> - Position 15 & 16 CE		

THREE WAY

1. Reverse acting actuators only.  
 2. Does not include spring or mounting kit.

# GTW SPECIFICATION FORM

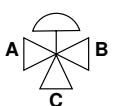
 <b style="font-size: 1.2em;">LESLIE CONTROLS, INC.</b> <small>A division of CIRCOR International, Inc.                  12501 Telecom Drive · Tampa, Florida 33637                  (813) 978-1000 · FAX: (813)-978-0984</small> <b style="font-size: 1.5em; color: blue;">CONTROL VALVE SPEC SHEET</b>	Project/Job _____ Unit/Customer _____ P.O./LCO File # _____ Item _____ Contract _____ MFR Serial# _____	Data Sheet _____ of _____ Spec _____ Tag _____ Dwg _____ Service _____																							
	Fluid <input type="checkbox"/> Steam <input type="checkbox"/> Other _____ Crit Pres PC _____																								
<b style="color: blue;">Service Conditions</b> Flow <input type="checkbox"/> #/hr <input type="checkbox"/> gpm <input type="checkbox"/> scfh <input type="checkbox"/> _____ Inlet Pressure <input type="checkbox"/> psig <input type="checkbox"/> psia <input type="checkbox"/> _____ Outlet Pressure <input type="checkbox"/> psig <input type="checkbox"/> psia <input type="checkbox"/> _____ Temperature <input type="checkbox"/> °C <input type="checkbox"/> °F _____ Max Press/Temperature: _____ / _____ Density/MW/SG _____ / _____ / _____ Viscosity _____ CP Vapor Pressure <input type="checkbox"/> psia <input type="checkbox"/> _____ Required C <sub>v</sub> _____ Noise (dBA) Allowable _____	<table border="1" style="width: 100%; border-collapse: collapse;"> <thead> <tr> <th style="width: 33%;">Max. Flow</th> <th style="width: 33%;">Norm. Flow</th> <th style="width: 33%;">Min. Flow</th> </tr> </thead> <tbody> <tr><td> </td><td> </td><td> </td></tr> <tr><td> </td><td> </td><td> </td></tr> <tr><td> </td><td> </td><td> </td></tr> <tr><td> </td><td> </td><td> </td></tr> <tr><td> </td><td> </td><td> </td></tr> <tr><td> </td><td> </td><td> </td></tr> <tr><td> </td><td> </td><td> </td></tr> </tbody> </table>	Max. Flow	Norm. Flow	Min. Flow																					
Max. Flow	Norm. Flow	Min. Flow																							
<b style="color: blue;">Line Info</b> Pipe Size In _____ /Sch _____ Pipe Size Out _____ /Sch _____																									
<b style="color: blue;">Valve, Body &amp; Bonnet</b> Body Size in. <input type="checkbox"/> 1/2 <input type="checkbox"/> 3/4 <input type="checkbox"/> 1 <input type="checkbox"/> 1 1/2 <input type="checkbox"/> 2 <input type="checkbox"/> 2 1/2 <input type="checkbox"/> 3 <input type="checkbox"/> 4 <input type="checkbox"/> 6 <input type="checkbox"/> 8 <input type="checkbox"/> 10 <input type="checkbox"/> 12 ANSI Class <input type="checkbox"/> 125 <input type="checkbox"/> 150 <input type="checkbox"/> 250 <input type="checkbox"/> 300 Body/Bonnet Material: <input type="checkbox"/> Cast Iron <input type="checkbox"/> Cast Steel <input type="checkbox"/> 316SS <input type="checkbox"/> Other _____ End Conn. Inlet/Outlet: <input type="checkbox"/> NPT <input type="checkbox"/> Int. Flanges <input type="checkbox"/> Other _____ Packing Material: <input type="checkbox"/> Teflon Chevron <input type="checkbox"/> BTG <input type="checkbox"/> Laminated Graphite																									
<b style="color: blue;">Trim Size</b> <input type="checkbox"/> 100%																									
<b style="color: blue;">Flow Path</b> <input type="checkbox"/> Mixing (Converging) (choose one outlet port) <input type="checkbox"/> Diverting (Diverging) (choose two outlet ports)																									
																									
<table border="1" style="width: 100%; border-collapse: collapse;"> <tr> <td style="width: 60%;">Outlet Port</td> <td style="width: 10%; text-align: center;"><b>A</b></td> <td style="width: 10%; text-align: center;"><b>B</b></td> <td style="width: 10%; text-align: center;"><b>C</b></td> </tr> <tr> <td>Close Port on Air Loss</td> <td style="text-align: center;"><input type="checkbox"/></td> <td style="text-align: center;"><input type="checkbox"/></td> <td style="text-align: center;"><input type="checkbox"/></td> </tr> </table>			Outlet Port	<b>A</b>	<b>B</b>	<b>C</b>	Close Port on Air Loss	<input type="checkbox"/>	<input type="checkbox"/>	<input type="checkbox"/>															
Outlet Port	<b>A</b>	<b>B</b>	<b>C</b>																						
Close Port on Air Loss	<input type="checkbox"/>	<input type="checkbox"/>	<input type="checkbox"/>																						
<b style="color: blue;">Actuator</b> Spring Action: <input type="checkbox"/> Air to Open <input type="checkbox"/> Air to Close <input type="checkbox"/> Last Position Available Air Supply Pressure: Max. _____ Min. _____ Manual Override: <input type="checkbox"/> Yes <input type="checkbox"/> No <input type="checkbox"/> Type _____																									
<b style="color: blue;">Solenoid</b> <input type="checkbox"/> Yes <input type="checkbox"/> No <input type="checkbox"/> Type _____ <input type="checkbox"/> Voltage _____																									
<b style="color: blue;">Positioner</b> <input type="checkbox"/> Yes <input type="checkbox"/> No <input type="checkbox"/> Type _____ <input type="checkbox"/> Pneu <input type="checkbox"/> I/P																									
<b style="color: blue;">Switch</b> <input type="checkbox"/> Yes <input type="checkbox"/> No <input type="checkbox"/> Type _____																									
<b style="color: blue;">Air Set</b> <input type="checkbox"/> Yes <input type="checkbox"/> No <input type="checkbox"/> Type: _____ <input type="checkbox"/> Range: _____																									
<b style="color: blue;">Other Accessories</b> <input type="checkbox"/> Yes <input type="checkbox"/> No <input type="checkbox"/> Type _____																									
<b style="color: blue;">Test</b> ANSI/FCI Leakage Class: <input type="checkbox"/> IV																									

**THREE WAY**

**QUESTIONS? CALL LESLIE CONTROLS @ (813) 978-1000 PLEASE FAX COMPLETED FORM TO: (813) 977-0174**