



**TYPE D50 DIRECT ACTING
PRESSURE REDUCING VALVE**

TYPE D50 PRESSURE REDUCING VALVE

PRESSURES to 300 PSIG at 420°F

- **Direct Acting**
- **Steam, Water or Gas**
- **Spherical Seating Surface on Floating Stainless Steel Disc for Tight Shutoff**
- **Four Spring Ranges**
- **Integral Stainless Steel Strainer**
- **ANSI/FCI 70-2 Class IV Shutoff**

OPTIONS

- Teflon® Disc for Dead-end Service for Liquid and Gas

Installation Tip: Add Uniflex Pipe Coupling for ease of maintenance
SEE PAGE 374

APPLICATION DATA

- Steam Irons
- Autoclaves
- Laundry Mangles
- Single Radiators
- Steam Tables
- Vulcanizers

VALVE RATINGS

Body Material	Pressure PSIG (bar)	Temperature °F (°C)
WITH ST. STL. DISC		
Cast Iron	200 (13.8)	@ 400 (204.4)
Bronze	300 (21.0)	@ 430 (215.6)
Stainless Steel	300 (21.0)	@ 420 (215.6)
WITH TEFLON® DISC		
All	300 (21.0)	@ 300 (148.9)
	200 (13.8)	@ 400 (204.4)

SPRING RANGES

3-15	All Sizes	75-140	1/2-1 1/4"
10-50	1/2-1 1/4"	30-100	1 1/2-2"
25-80	1/2-1 1/4"	10- 40	1 1/2-2"

Canadian Registration # OC 0591.9C

SIZING INFO
PAGE 135

RATED FLOW COEFFICIENTS (Cv)

VALVE SIZE					
1/2	3/4	1	1 1/4	1 1/2	2
2.2	3.3	4.9	5.0	10.1	10.8



TYPE D50 PRESSURE REDUCING VALVE

SPECIFICATION

The valve shall be self operated, requiring no external energy source. The valve shall operate quickly and provide dead end shut-off. The body materials and rating shall be cast iron for 200 psig and 400°F, Bronze or Stainless Steel for 300 psi and 420°F. Valve trim material is to be stainless steel. Valve to have a standard aspirator to allow for adjustment of operation.

MATERIALS OF CONSTRUCTION

Body, Cast IronASTM 126 Cl. B
 Body, BronzeASTM B61-80 UNS C92200
 Body, St. Stl.....ASTM 743 CF-8M
 Stem304 St. Stl ASTM 276 Cond. A
 Disc.....316 St. Stl. ASTM 276 Cond. A
 Seat304 St. Stl ASTM 276 Cond. A
 Gasket.....Teflon
 Diaphragm304 St. Stl ASTM 276 Cond. A
 Spring302 St. Stl.

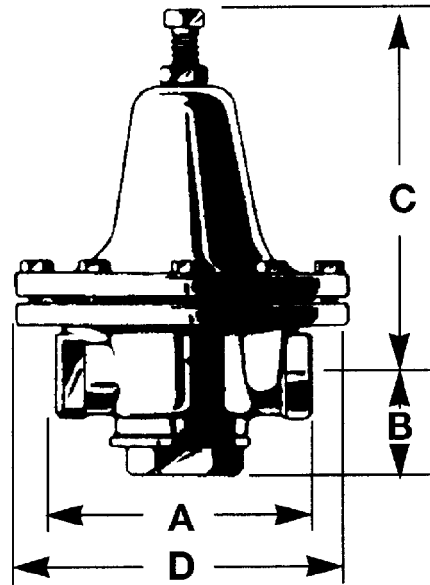

**TYPE D50 DIRECT ACTING
PRESSURE REDUCING VALVE**

**D50 PRESSURE
REDUCING VALVE**

DIMENSIONS inches (mm) AND WEIGHTS pounds (kg)

Body Mat'l.	Size	Dimensions, Inches				Weight (lbs.)
		A	B	C	D	
C.I. & Brz	1/2, 3/4 (13, 19)	4 5/8 (143)	1 3/4 (44)	6 7/8 (175)	6 (152)	12 (5.5)
C.I.	1, 1 1/4 (25, 32)	5 5/8 (143)	2 (51)	7 1/4 (184)	7 1/2 (191)	19 (8.6)
C.I.	1 1/2, 2 (38, 51)	6 5/8 (168)	2 3/4 (70)	11 1/2 (292)	9 (229)	30 (13.6)
St. Stl.	1/2 (13)	5 (127)	1 5/8 (41)	5 1/2 (140)	4 7/8 (124)	8 (3.6)
St. Stl.	3/4, 1 (19, 25)	5 5/8 (143)	2 1/4 (57)	6 1/2 (165)	7 7/16 (191)	22 (10)

RATED STEAM, AIR AND WATER CAPACITY TABLE

TYPE D50 DIRECT ACTING PRESSURE REGULATOR

VALVE SIZE		1/2"			3/4"			1"			1 1/4"			1 1/2"			2"		
IN	OUT	2.2			3.3			4.9			5.0			10.1			10.8		
		S	A	W	S	A	W	S	A	W	S	A	W	S	A	W	S	A	W
10	5	41	14	3	59	20	4.2	80	27	5.7	91	30	6.5	105	35	7.4	120	40	8.5
20	10	68	23	4.2	97	33	6.0	130	44	3.1	150	50	9.2	170	57	10	230	77	14
30	10	100	35	5.9	145	50	8.5	195	67	11	220	76	13	250	87	15	290	100	17
40	30	87	29	4.2	125	42	6.0	170	57	8.1	190	64	9	250	85	12	265	89	13
50		130	43	5.9	185	63	8.5	250	84	11	285	95	13	375	125	17	395	130	18
75		200	72	8.8	290	105	13	390	140	17	440	160	19	580	210	25	610	220	27
100		255	98	11	370	140	16	495	190	21	565	215	24	740	285	32	780	295	33
125		315	105	13	450	175	19	605	240	25	690	270	28	900	355	37	950	375	39
150		370	145	15	530	210	21	715	285	28	810	325	32	1065	425	42	1120	445	44
175		425	170	16	615	245	23	825	330	31	935	375	35	1230	495	46	1290	520	48
200		480	195	17	695	280	25	930	375	33	1060	430	38	1390	560	50	1460	590	52
250	595	240	20	855	350	28	1150	470	38	1305	535	43	1710	700	56	1800	735	60	
60	50	115	38	4.6	165	55	6.6	250	85	10	260	87	10	355	120	14	395	130	16
75		190	63	7.2	275	92	10	420	140	16	430	145	17	585	195	23	655	220	25
85		230	77	8.5	335	110	12	510	170	19	525	175	20	715	240	27	800	270	30
100		280	96	10	410	140	15	625	215	23	645	220	23	875	300	32	1000	335	35
125		340	125	12	500	185	18	760	280	28	785	290	29	1070	390	39	1190	435	43
150		405	155	14	590	225	21	895	340	32	925	350	33	1260	480	45	1400	535	50
175		465	180	16	675	265	23	1030	400	36	1065	415	37	1450	565	50	1620	630	56
200		525	205	18	765	305	26	1170	460	39	1205	475	40	1640	650	55	1830	720	61
250	650	260	20	945	380	30	1440	580	45	1485	595	47	2020	815	65	2260	905	71	
85	75	130	44	4.6	190	64	6.6	290	98	10	300	100	10	410	140	14	455	155	16
100		215	72	7.2	315	105	10	480	160	16	495	165	17	675	225	23	750	250	25
125		325	110	10	470	160	15	720	240	23	740	250	23	1010	340	32	1130	380	35
150		405	140	12	590	205	18	895	310	28	925	320	29	1260	440	39	1400	485	43
175		465	170	14	675	245	21	1030	375	32	1065	390	33	1450	530	45	1620	590	50
200		525	200	16	765	290	23	1170	440	36	1205	455	37	1640	620	50	1830	685	56
225		585	225	18	855	330	26	1300	500	39	1345	515	40	1830	705	55	2040	785	61
250		650	250	19	945	370	28	1440	560	42	1485	580	44	2020	790	60	2250	880	66
110	100	190	65	6	310	105	9	380	125	12	400	135	12	465	155	14	515	170	16
125		310	105	9	500	170	15	620	210	19	655	220	20	755	255	23	840	280	25
150		460	155	13	745	250	21	920	310	26	970	325	28	1120	375	32	1250	415	35
200		675	235	19	1095	385	30	1350	475	37	1430	500	39	1650	575	45	1830	640	50
225		755	275	21	1220	445	34	1510	550	41	1590	580	44	1840	665	50	2040	740	56
250		830	310	23	1350	505	37	1670	620	45	1760	655	48	2030	760	55	2250	840	61
135	125	210	70	5.9	340	115	9.5	420	140	12	440	150	12						
150		340	115	9.3	550	185	15	680	225	19	715	240	20						
175		500	165	13	810	270	21	995	335	26	1050	350	28						
200		635	210	16	1030	345	26	1270	425	32	1340	450	34						
225		755	255	19	1230	410	30	1510	505	37	1500	535	39						
250	830	295	21	1350	475	34	1670	585	41	1760	615	44							
160	140	315	105	8.3	510	170	13	630	210	17	665	225	17						
175		425	145	11	690	230	18	855	285	22	900	300	23						
200		580	195	14	940	315	23	1160	390	29	1220	410	30						
225		710	240	17	1150	385	28	1420	475	34	1500	505	36						
250		835	280	19	1350	455	31	1670	560	39	1760	590	41						

S — Steam (#/hr.)
A — Air (SCFM)
W — Water (GPM)



SIZING D50 DIRECT ACTING PRESSURE REGULATOR

EXAMPLE 1 FOR CONDITIONS WITHIN CAPACITY TABLE

Given an initial steam pressure of 100 PSIG and a required flow of 500 #/hr. at a reduced pressure of 30 PSIG, determine droop, minimum controllable flow pressure and valve size.

In the Capacity Table opposite, the droop has been fixed at 25% of the maximum range of the adjusting spring. Therefore, for a 30 PSIG delivery pressure, a 25-80 adjusting spring would be selected. Thus, the droop is (25% x 80 = 20) 20 PSI. Minimum controllable flow pressure = Reduced Pressure + Droop = 30 + 20 = 50 PSIG

Entering the Capacity Table at a minimum controllable flow pressure (OUT) of 50 PSIG, an initial pressure (IN) of 100 PSIG, the smallest valve size capable of delivering 500 #/hr. is the 1" size.

EXAMPLE 2 FOR CONDITIONS OUTSIDE CAPACITY TABLE

Given an initial steam pressure of 150 psig and a required flow of 900 #/hr. at a reduced pressure of 25 PSIG, determine the valve size, droop and minimum controllable flow pressure.

$$\frac{P_2}{P_1} = \frac{(25 + 14.7)}{(150 + 14.7)} = \frac{39.7}{164.7} = .24 \quad \text{thus } P_2 = .24P_1 < .58P_1$$

Therefore, use Critical Flow Cv formula:

$$C_v = \frac{W}{1.71P_1} = \frac{900}{1.71(150 + 14.7)} = \frac{900}{1.71(164.7)} = 3.2$$

Referring to the C_v line of the Capacity Table opposite, the 3/4" valve size ($C_v = 3.3$) is the smallest valve with the required capacity.

Droop is a function of valve size (3/4"), regulator capacity in percent [(3.2 ÷ 3.3) x 100 = 97%] and adjusting spring range (10-30). Enter the 3/4" Valve Droop Chart (below) at 97% and draw a line upward until you intersect the 10-30 curve. From there, draw a line left to the vertical axis. Droop in this case is 11 PSIG.

Minimum Controllable Flow Pressure = Reduced Pressure + Droop = 25 + 11 = 36 PSIG

Repeating the above procedure substituting a 1" valve size with a maximum C_v of 4.9, droop would be 8 PSIG and minimum controllable flow pressure would be 33 PSIG.

1/2" VALVE DROOP CHART

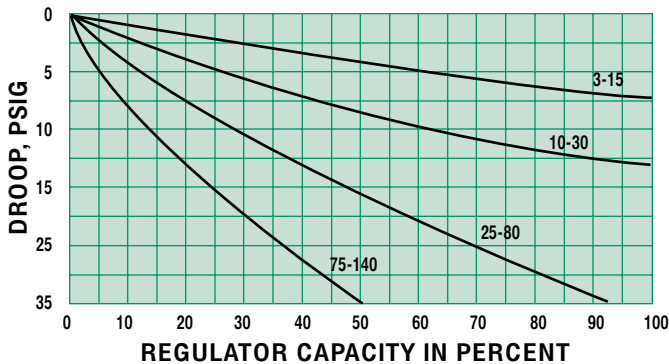

3/4" VALVE DROOP CHART

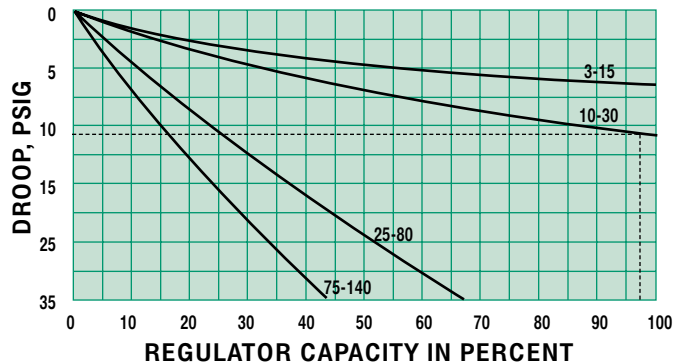

1" & 1 1/4" VALVE DROOP CHART

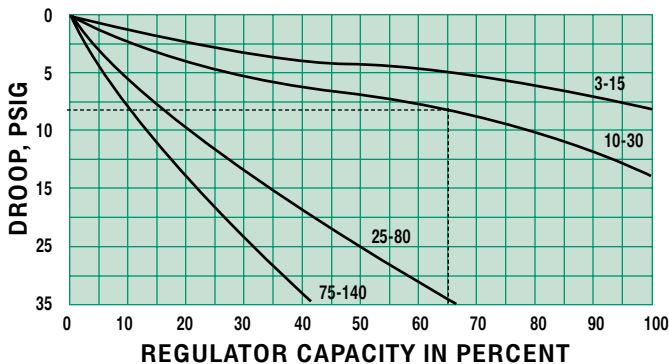

1 1/2" & 2" VALVE DROOP CHART

