

# Stand-Alone Pumps CAST DUCTILE IRON TANK

Condensate  
Pumps

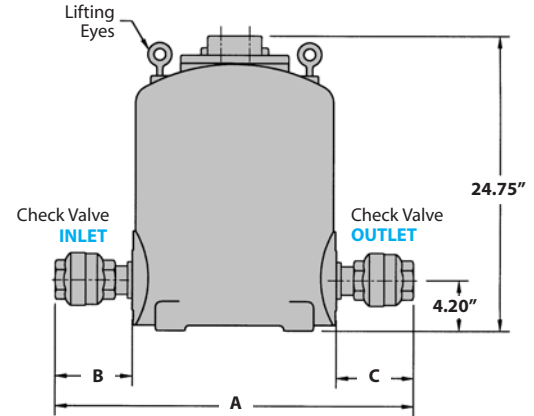

Model	<b>PMPC</b>
Body	<b>Ductile Iron</b>
Cover	<b>Ductile Iron</b>
Check Valves	<b>Stainless Steel</b>
PMO Max. Operating Pressure	<b>200 PSIG</b>
TMO Max. Operating Temperature	<b>388°F</b>
PMA Max. Allowable Pressure	<b>200 PSIG @ 650°F</b>
TMA Max. Allowable Temperature	<b>650°F @ 200 PSIG</b>

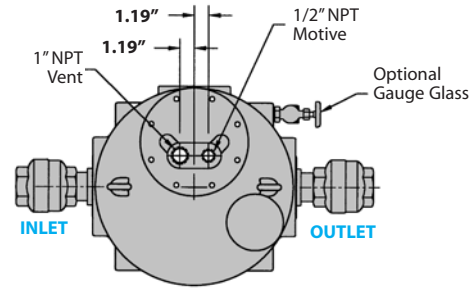

## Typical Applications

The **PMPC model Ductile Iron** non-electric pressure motive pump is typically used when liquids must be moved to higher elevation, higher pressure or extended distances. This stand-alone pump is capable of operating with a maximum motive pressure of 200 PSIG provided by steam, air or other gas supply. **ASME "UM" code stamp is available.**

## Features

- Equipped with our **Patented "Snap-Assure"** Mechanism which **extends the useful life of the pump**
- Mechanism incorporates **heat-treated stainless steel wear items**
- All stainless steel internals for ultimate corrosion resistance
- Dual compression springs made from Inconel-X-750 for high-temperature corrosive service
- Operates using steam, air, nitrogen or other pressurized gases as the motive force
- Non-Electric** – can be used in remote locations or NEMA 4, 7, 9 and hazardous areas

## Sample Specification

The non-electric pressure powered pump shall be capable of operating with a maximum motive pressure of 200 PSIG provided by steam, air or other gas supply. The pump body shall be cast ASTM A-395 Ductile Iron capable of an ASME "UM" code stamp if requested. The pump mechanism shall be float operated with a patented "Snap-Assure" feature constructed of all stainless steel materials with all load bearing points hardened for extended service life. The mechanism shall feature two Inconel springs used in compression with motive & vent valves hardened to 40c Rockwell.

## DIMENSIONS – inches

Size (Inlet x Outlet)	Model Code	A	B	C	Weight (lbs)
1" x 1"	<b>PMPC-1X1-N-SS</b>	29 <sup>1</sup> / <sub>2</sub>	6	6	360
1 <sup>1</sup> / <sub>2</sub> " x 1"	<b>PMPC-1.5X1-N-SS</b>	30 <sup>3</sup> / <sub>4</sub>	7 <sup>1</sup> / <sub>2</sub>	6	365
1 <sup>1</sup> / <sub>2</sub> " x 1 <sup>1</sup> / <sub>2</sub> "	<b>PMPC-1.5X1.5-N-SS</b>	31 <sup>1</sup> / <sub>4</sub>	7 <sup>1</sup> / <sub>2</sub>	7 <sup>1</sup> / <sub>2</sub>	367
2" x 1"	<b>PMPC-2X1-N-SS</b>	31	8	6	370
2" x 1 <sup>1</sup> / <sub>2</sub> "	<b>PMPC-2X1.5-N-SS</b>	32 <sup>1</sup> / <sub>2</sub>	8	7 <sup>1</sup> / <sub>2</sub>	380
2" x 2"	<b>PMPC-2X2-N-SS</b>	32 <sup>3</sup> / <sub>4</sub>	8	8	385
3" x 2"	<b>PMPC-3X2-N-SS</b>	35 <sup>1</sup> / <sub>4</sub>	9 <sup>1</sup> / <sub>4</sub>	8	390

The PMPC Stand Alone Pump consists of pump tank, internal mechanism, and inlet and outlet stainless steel check valves.

## MATERIALS

Body & Cover	<b>Ductile Iron</b>
Cover Gasket	Grafoil
Cover Bolts	Steel
Inlet Valve	Hardened Stainless Steel 40 Rc
Vent Valve	Hardened Stainless Steel 40 Rc
Mechanism Yoke	304 Stainless Steel
Ball Float	304 Stainless Steel
Check Valves	Stainless Steel
Springs	Inconel-X-750
Other Internal Components	Stainless Steel

Snap-Assure U.S. Patent No. 6572340

**Sizing & Selection** - Liquid Capacity in lbs/hr using steam as motive media at indicated filling head

Motive Pressure	Total Back Pressure	PMPLS	PMPC, PMPF, PMPSS*								
		1" X 1"	1 1/2" X 1"	1 1/2" X 1 1/2"	2" X 1"	2" X 1 1/2"	2" X 2"	3" X 2"	3" X 2"	3" X 2"	3" X 2"
		6" Head	12" Head	12" Head	12" Head	12" Head	12" Head	12" Head	12" Head	Duplex	Triplex
5	2	1760	1860	1920	2860	3180	3540	5000	10000	15000	20000
10	5	1870	2200	2450	4350	4840	5380	7210	14420	21630	28840
10	2	2200	3030	3370	6880	7650	8500	1110	22220	33330	44440
25	15	1650	2130	3480	4990	5550	6170	8230	16460	24690	32920
25	10	1980	3600	3990	6560	7290	8100	10780	21560	32340	43120
25	5	2300	4700	5200	7970	8860	9850	13350	26700	40050	53400
50	40	1650	2280	2530	3370	3750	4170	5670	11340	17010	22680
50	25	1980	4050	4500	6800	7560	8400	11550	23100	34650	46200
50	10	2300	4700	5240	7970	8860	9850	13440	26880	40320	53760
75	60	1540	2400	2660	3600	4000	4440	6340	12680	19020	25360
75	40	1980	3780	4190	5920	6580	7320	9870	19740	29610	39480
75	15	2420	5130	5700	8580	9540	10600	14330	28660	42990	57320
100	80	1650	2750	3060	4160	4630	5150	6860	13720	30580	27440
100	60	1870	3600	4000	5560	6180	6870	9100	18200	27300	36400
100	40	2090	4700	5210	6880	7650	8500	11270	22540	33810	45080
100	15	2420	5400	6010	8740	9720	10800	14330	28660	42990	57320
125	115	1430	2380	2640	3270	3640	4050	4960	9220	14880	19840
125	100	1540	2980	3300	4140	4600	5130	6390	12780	19170	25560
125	80	1760	3430	4100	5400	6000	6670	8540	17080	25620	34160
125	60	1980	4170	4850	6600	7340	8160	10530	21060	31590	42120
125	40	2200	5100	6950	7760	8630	9590	12500	25000	37500	50000
125	15	2420	5850	6660	9240	10270	11420	15100	30200	45300	60400
150	120	1590	2650	2940	3400	3780	4200	5690	11380	17070	33760
150	100	1640	2150	3490	4320	4800	5350	7000	14000	21000	28000
150	80	1860	3800	4230	5490	6100	6770	9100	18200	27300	36400
150	60	2080	4500	5000	6660	7400	8240	11120	22240	33360	44480
150	40	2300	5290	5870	7920	8800	9780	13220	26440	39660	52880
150	15	2520	6100	6820	9450	10500	11680	15500	31000	46500	62000
175	120	1680	2870	3150	3580	4000	4450	5960	11920	17880	23840
175	100	1770	3370	3720	4500	5000	5590	7700	15400	23100	30800
175	80	1980	3960	4470	5680	6350	6920	9440	19880	28320	37760
175	60	2210	4740	5240	6900	7580	8350	11480	22960	34440	45920
175	40	2420	5600	6040	8150	8920	9880	13550	27100	40650	54200
175	15	2630	6260	6970	9750	10520	11680	15780	31560	47340	63120
200	120	1800	3090	3350	3720	4190	4680	6270	12540	18810	24080
200	100	1810	3600	3940	4680	5190	5800	8020	16040	24060	32080
200	80	2100	4160	4660	5820	6520	7080	9720	19440	29160	38880
200	60	2330	4950	5450	7080	7720	8480	11800	23600	35400	47200
200	40	2530	5790	6220	8400	8900	10040	13900	27800	41700	55600
200	15	2740	6440	7080	1000	10700	11880	16080	32160	48240	64320

\* PMPSS is rated to only 150 PSIG

## Vented Receiver Sizing

Vented Receiver Sizing			
Flash Steam up to --	Receiver		Vent Line Dia.
	Dia.	Length	
75 pph	4"	36"	1"
150 pph	6"	36"	2"
300 pph	8"	36"	3"
600 pph	10"	36"	4"
900 pph	12"	36"	6"
1200 pph	16"	36"	6"
2000 pph	20"	60"	8"
3000 pph	24"	60"	8"
4000 pph	26"	60"	10"
5000 pph	28"	60"	10"
6000 pph	30"	72"	12"
7000 pph	32"	72"	12"
8000 pph	36"	72"	14"

When sizing a Pressure Motive Pump for an atmospheric return system, the amount of flash steam to be vented through the receiver must be calculated. Vent sizing is critical to maintain zero psig in the receiver tank to allow free drainage of low pressure systems. Undersized vents will cause gradual pressure increase in the receiver. This impedes drainage from the condensate source, and can cause water logging of the system.

### To Size Receiver & Vent:

Usually the condensate load to be pumped comes from multiple sources. For each source determine the pressure and condensate load (lbs/hr). Enter the "Percent Flash Steam" table in the condensate pressure column and move right until under the appropriate flash tank pressure. This number is the percentage of condensate that will flash into steam. Now take the condensate load and multiply it by the decimal value of the flash steam percentage to calculate the amount (lbs/hr) of flash steam. Repeat this for all condensate sources and total the flash steam. Enter the "Vented Receiver Sizing" table with the total flash steam load to determine the correct sizes for receiver and vent.

Percent Flash Steam											
Condensate Pressure (PSIG)	Flash Tank Pressure (PSIG)										
	0	2	5	10	15	20	30	40	60	80	100
5	1.6	0.9	0								
10	2.9	2.2	1.3	0							
15	3.9	3.3	2.4	1.1	0						
20	4.9	4.2	3.3	2.1	1	0					
30	6.5	5.8	5	3.7	2.6	1.7	0				
40	7.8	7.2	6.3	5.1	4	3	1.4	0			
60	10	9.4	8.5	7.3	6.2	5.3	3.7	2.3	0		
80	12	11	10	9.1	8.1	7.1	5.5	4.2	1.9	0	
100	13	13	12	11	9.6	8.7	7.1	5.8	3.5	1.6	0
125	15	14	14	12	11	10	8.8	7.5	5.3	3.4	1.8
150	16	16	15	14	13	12	10	9	6.8	4.9	3.3
200	19	18	17	16	15	14	13	12	9.4	7.6	6
250	21	20	19	18	17	16	15	14	12	9.8	8.2
300	23	22	21	20	19	18	17	16	13	12	10
350	24	24	23	22	21	20	18	17	15	13	12
400	26	25	24	23	22	21	20	19	17	15	14

# Series PMPC, PMPF, PMPSS & PMPLS Pressure Motive Pumps

## Installation

## Operation &

## Maintenance

## Manual



PMPC



428 Jones Boulevard  
Limerick Airport Business Center  
Pottstown, PA 19464

Fax: (610)495-5134  
[www.watsonmcdaniel.com](http://www.watsonmcdaniel.com)

Phone: (610)495-5131

## **Safety Considerations**

**Follow installation guidelines to ensure the product functions properly and as intended.**

Improper installation and use may result in such hazards as damage to the product or malfunctions that may lead to injuries or damage. Failure of the product to function may result in problems occurring in the system, such as equipment flooding with condensate or improper drainage.

See page 10 & 11 for System Troubleshooting.

**When disassembling or removing the product, wait until the internal pressure is relieved and the product has cooled to room temperature.**

Disassembling or removing the product when it is hot or under pressure may lead to injuries or damage.

**Do not excessively over tighten or torque when connecting piping to the product.**

Over-tightening may cause cracks and damage to the product which may lead to fluid discharge, which may cause injuries.

## **Applications**

The Pressure Motive Pump is recommended when liquids must be moved to a higher elevation, higher pressure, or greater distances. Typical applications are:

- Draining condensate from multiple sources such as drip, tracing, and process steam traps
- Draining condensate with High Temperatures and High Back Pressure return piping.
- For Remote Installation (i.e. Tank Farms)
- Where Electricity is Prohibited (i.e., some underground steam distribution systems, tank farms, etc.)
- Draining in Submersible, Hard-To-Access Areas.

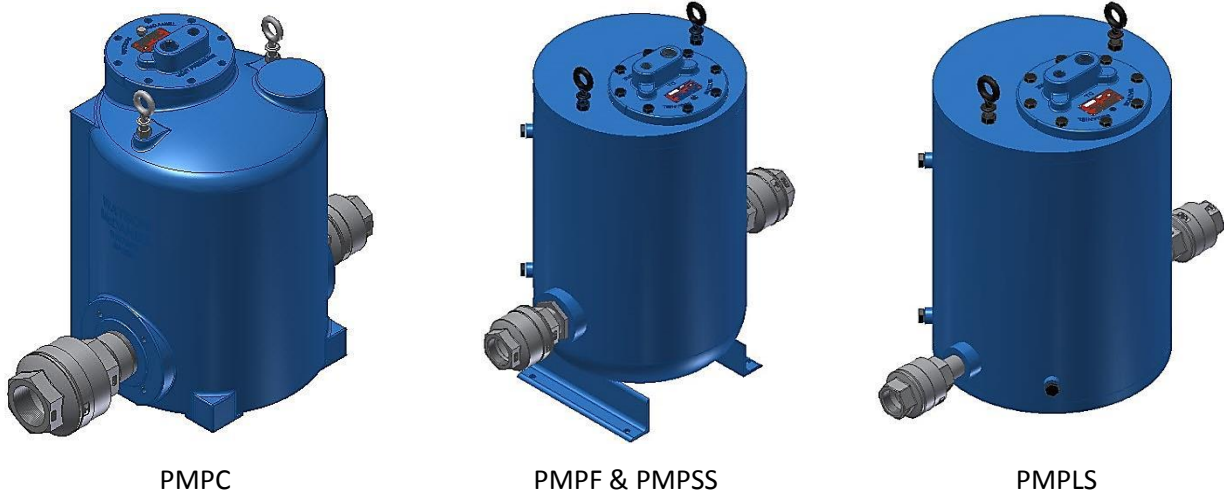

**Figure 1: PMP Series Models**

<b>PMP Series Assembly Materials</b>		
<b><u>DESCRIPTION</u></b>	<b><u>MODEL</u></b>	<b><u>MATERIAL</u></b>
BODY	PMPC	DUCTILE IRON
	PMPSS	304L SST
	PMPF, PMPLS	CARBON STEEL
COVER	PMPC	DUCTILE IRON
	PMPSS	304L SST
	PMPF, PMPLS	CARBON STEEL
COVER GASKET	ALL	NON ASBESTOS
COVER BOLTS	ALL	STEEL
MECHANISM	ALL	S.ST.
SPRINGS	ALL	INCONEL
CHECK VALVES	ALL	S.ST.

Each Watson McDaniel Company Product is warranted against defects in material and workmanship for one year from date of shipment. This warranty extends to the first retail purchaser only. All defective material must be returned to the person from whom you purchased the Product, transportation prepaid, free of any liens or encumbrances, and if found to be defective will be repaired free of charge or replaced, at the warrantor's or seller's option. If the material is replaced, any replacement will be invoiced in the usual manner and after inspection of alleged defective material an adjustment will be made for depreciation caused by purchaser's use. In no event will Watson McDaniel Company be liable to do more than refund the original contract price. Incidental and consequential damages are excluded, whether under this warranty or otherwise. All implied warranties, including warranties of merchantability and fitness for a particular purpose, are disclaimed and excluded.

# PMP Specifications

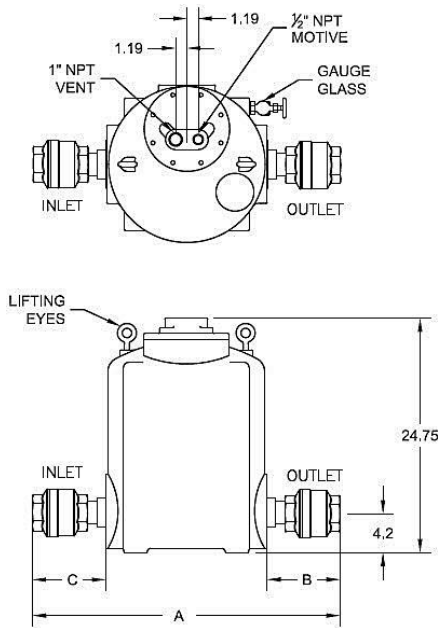

Figure 2: PMPC Dimensions

PMPC Dimensions (inches)			
SIZE	A	B	C
1" x 1"	29 1/2	6	6
1-1/2" x 1"	30 3/4	7 1/2	6
1-1/2" x 1-1/2"	31 3/4	7 1/2	7 1/2
2" x 1"	31	8	6
2" x 1-1/2"	32 1/2	8	7 1/2
2" x 2"	32 3/4	8	8
3" x 2"	35 1/4	9 1/4	8

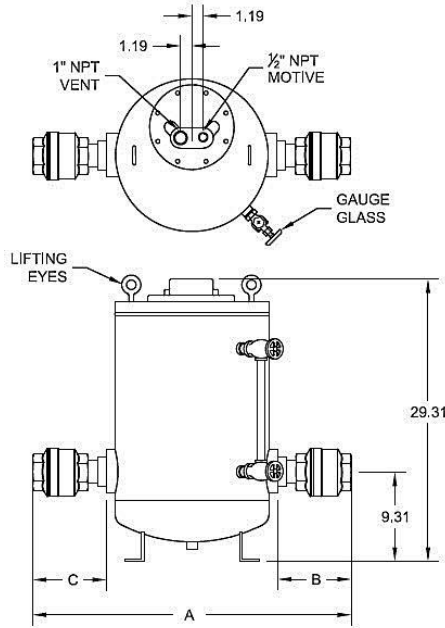

Figure 3: PMPF/SS Dimensions

PMPF/SS Dimensions (inches)			
SIZE	A	B	C
1" x 1"	30 1/2	6	6
1-1/2" x 1"	31 3/4	7 1/2	7 1/2
1-1/2" x 1-1/2"	32 3/4	7 1/2	6
2" x 1"	32	8	6
2" x 1-1/2"	33 1/2	8	7 1/2
2" x 2"	33 3/4	8	8
3" x 2"	35 1/4	9 1/4	8

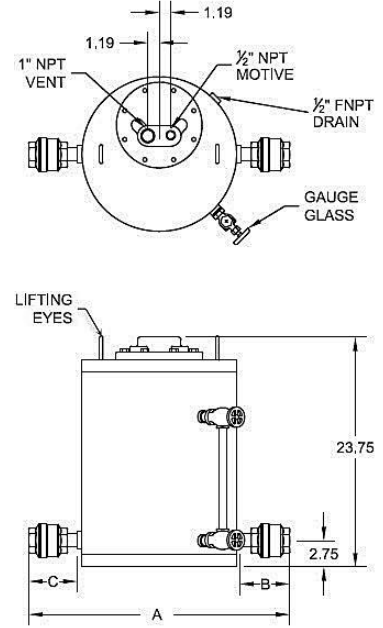

Figure 4: PMPLS Dimensions

PMPLS Dimensions (inches)			
SIZE	A	B	C
1" x 1"	30 1/2	6	6
1-1/2" x 1"	31 3/4	7 1/2	7 1/2
1-1/2" x 1-1/2"	32 3/4	7 1/2	6

PMP Pressure-Temperature Ratings					PMP Operating Conditions				Weights
	PMO	PMA	TMO	TMA	Avg. Instantaneous Discharge Rate	Avg. Pump Discharge per Cycle	Avg. Steam Consumption	Avg. Air Consumption	
<b>PMPC</b>	200 PSIG	200 PSIG @ 650°F	388°F	650°F	max, 90 gpm	8.4 gal	3 lbs. per 1000 lbs. liquid	100 SCF per 1000 lbs. liquid	310 lbs.
<b>PMPSS</b>	150 PSIG	150 PSIG @ 650°F	366°F	650°F	max, 90 gpm	8.4 gal	3 lbs. per 1000 lbs. liquid	100 SCF per 1000 lbs. liquid	250 lbs.
<b>PMPF</b>	200 PSIG	250 PSIG @ 650°F	388°F	650°F	max, 90 gpm	8.4 gal	3 lbs. per 1000 lbs. liquid	100 SCF per 1000 lbs. liquid	250 lbs.
<b>PMPLS</b>	150 PSIG	150 PSIG @ 650°F	366°F	650°F	max. 30 gpm	8.4 gal	3 lbs. per 1000 lbs. liquid	100 SCF per 1000 lbs. liquid	230 lbs.

Each Watson McDaniel Company Product is warranted against defects in material and workmanship for one year from date of shipment. This warranty extends to the first retail purchaser only. All defective material must be returned to the person from whom you purchased the Product, transportation prepaid, free of any liens or encumbrances, and if found to be defective will be repaired free of charge or replaced, at the warrantor's or seller's option. If the material is replaced, any replacement will be invoiced in the usual manner and after inspection of alleged defective material an adjustment will be made for depreciation caused by purchaser's use. In no event will Watson McDaniel Company be liable to do more than refund the original contract price. Incidental and consequential damages are excluded, whether under this warranty or otherwise. All implied warranties, including warranties of merchantability and fitness for a particular purpose, are disclaimed and excluded.

## Principle of Operation

The Pressure Motive Pump allows discharge of high-temperature condensate for return to the boiler. They can also be used to discharge water and other liquids for transfer to other locations. The PMP Series Pumps are intended to work in an open loop (vented) system.

A Pressure Motive Pump consists of a pump tank, float with internal operating mechanism, and a set of inlet and outlet check valves to control direction of flow and capacity. The positions of the vent and motive valves control the filling and discharge of the pump. The vent valve will be open during the filling cycle to allow air or steam in the pump to be displaced as water enters the pump. As the pump fills, the float rises until it reaches its upper "trip point". Once the pump becomes filled and the mechanism "trips", the vent valve closes and pressurized gas enters the tank through the motive line to push condensate out of the pump and into the downstream return line.

1. When the pump is in the normal start up position, the float mechanism will be at its lowest point with the vent valve open and the motive pressure valve closed.

2. As condensate fills the pump, the float mechanism begins to rise.
3. The float mechanism will continue to rise until it reaches the upper trip point. When the spring loaded mechanism reaches the trip point, it snaps over the center and the motive pressure valve opens and the vent valve closes.
4. When the motive valve opens, pressurized gas enters the tank to discharge condensate through the outlet check valve. A check valve placed at the condensate inlet will stop the condensate from being pumped back into the receiver. Because the tank is now pressurized condensate is unable to flow from the receiver to the pump. As the condensate flows out of the pump under the motive pressure, the float begins to drop.
5. When the float reaches the low trip point, the mechanism snaps over the center and the motive pressure valve closes and the vent valve opens. The pressure in the pump is released and the condensate is able to once again flow from the receiver down into the pump.



**Figure 5: PMPC Cutaway View**



**Figure 6: PMPF Cutaway View**



## **Installation – Open Loop (Vented) System\***

1. The pump must be installed standing in the vertical position and located below the equipment to be drained. It is important that the preferred operating filling head be established from the top of the pump body to the underside of a receiver. The standard operating fill head is 12". Fill head is determined from bottom of drain point to top of pump. See 'Fill Head' in Figure 7. Pump capacity can be increased by increasing the fill head. In instances where space is limited a vertical receiver may be used.
2. **Vented Receiver:** A vented receiver should be installed before and above the pressure motive pump to neutralize the pressure from all condensate sources. If you will be using an existing tank or fabricated one, be sure to verify that the vessel is properly sized and vented for the application. Please consult our sizing guide on Page 10 of this instruction manual. When installing receiver, be sure to follow fill head requirements.
3. If needed, connect the inlet and outlet check valves to the pump. Check valves should be installed as close to the pump as possible. In most instances check valves are factory installed. Consult factory if considering mounting check valves further away from the pump or in the vertical. **Caution:** Make sure that the flow arrows on the check valves are oriented in the proper direction. For optimum performance, horizontal pipe runs immediately before and after the check valves should be kept as short as possible. Pipe up the pump inlet check valve to the receiver and outlet check to the discharge line. It is recommended that full port isolation valves be used for the pump, matching the line size.
4. Connect the operating steam supply pressure to the motive inlet connection (1/2" FNPT) at the top of the pump head. A PRV may be installed on the motive line to reduce motive pressure to the pump. Motive pressure line should always be equipped with an isolation valve, strainer and a steam trap. The motive steam drip trap condensate discharge may be piped to the top of the receiver, pump discharging line, or directly into a condensate return header. For optimum performance and service life, it is recommended that the motive pressure be 10-15 psig higher than the system back pressure. If more capacity is required, motive pressure can be increased, but should not exceed the maximum operating pressure of the pump.
5. **Pump Vent/Exhaust Line:** Install a pipe line from the pump vent connection (1" FNPT) to the top of the receiver. Install vent piping with a slight slope as to not create any low points. This piping is extremely important to ensure the vent does not become obstructed and for proper operation of the pump and system.
6. **Considerations for Multi-Pump Systems**  
A multi-pump system should be considered when load requirements exceed single pump capacities or where a redundant pump(s) is required. A receiver should be sized large enough to handle condensate load and flash steam. When installing a multi-pump system, larger motive inlet piping may be required to allow adequate motive distribution to each pump. When tying together each PMP vent outlet, larger sized piping may be required as to not restrict flow. Size condensate return piping to accommodate capacity of multiple drain points. As a general guideline, return piping should be sized to keep condensate velocity at or below 6 ft/s.  
  
For Multi-Pump System Installations, consult factory for engineering and installation.  
  
\*Note: For Closed Loop Pump-Trap Systems, refer to WPT or PMPT Manual.

## Start up

1. Gradually open steam supply to provide pressure at the pump motive inlet. Make sure the motive valve is operational and drip trap is functioning properly.
2. Completely open the full port isolation valves in the pump condensate inlet and outlet lines as well as any isolation valves in the pump vent/exhaust line.
3. Open the isolation valve(s) ahead of the pump receiver allowing condensate to enter the vessel and begin to fill the pump body below it. Pump will discharge when full.
4. Carefully observe the PMP unit. The pump(s) should cycle periodically with an audible sound (depending on surrounding noise levels) at the end of each pumping cycle. If any irregularities are observed, recheck installation and start-up instructions for proper procedure, or call the applications engineering department for assistance.
5. If overflow piping has been provided, check that a water seal has been established to prevent any steam from being vented in normal operation. Prime piping if necessary.

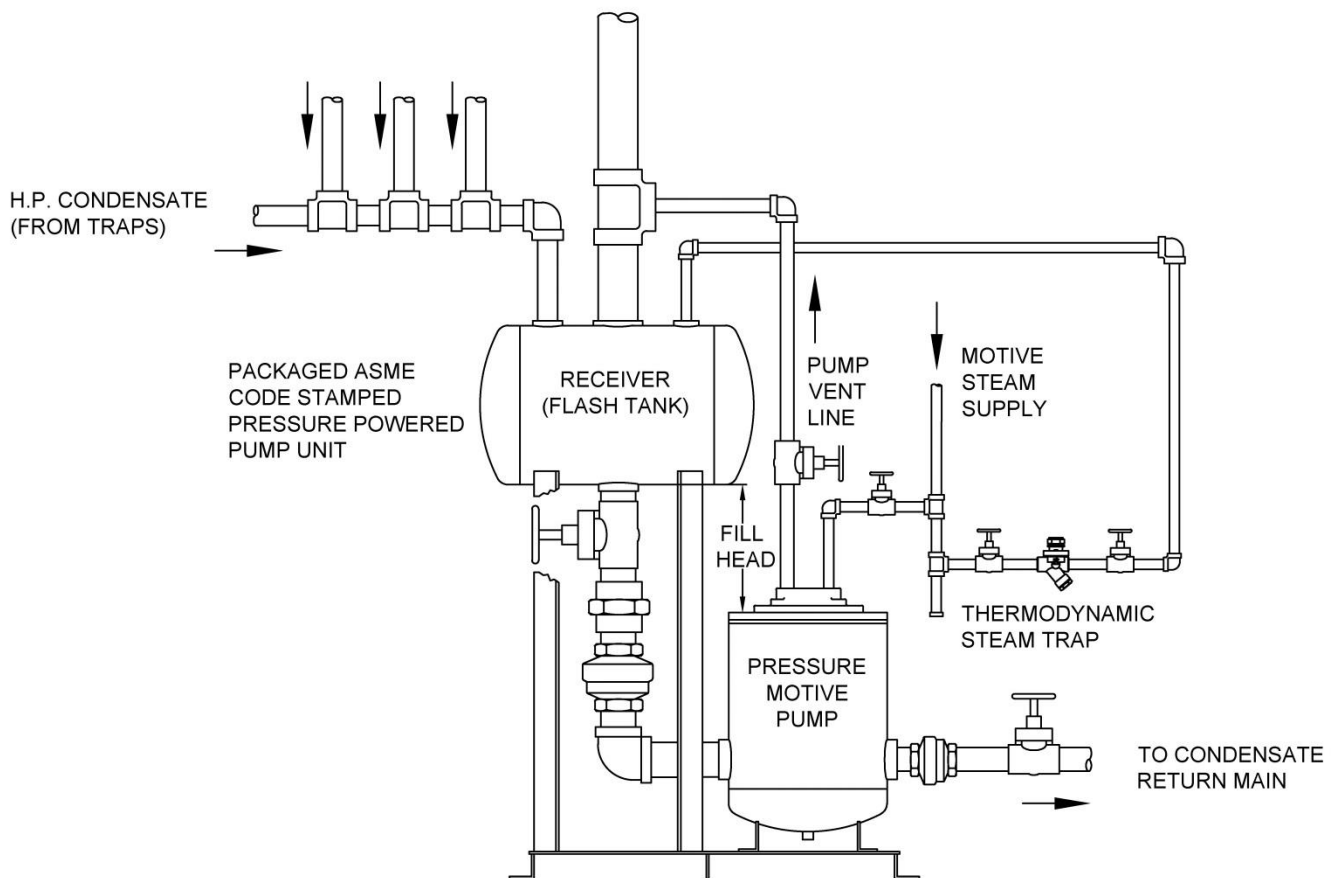

**Figure 7: Open Loop Pump System**

## Maintenance

Close all pump isolation valves. Make certain no pressure is trapped in the system. Allow unit and piping to cool to room temperature.

1. Remove the motive pressure and vent piping connections. Remove bolts from top cover and lift complete mechanism out of pump body.
2. Inspect mechanism for wear, dirt, and scale. Make sure the mechanism moves as intended. Remove check valves and inspect for any dirt or debris that could be obstructing the valve. Clean seating surfaces of check valves then reinstall or replace if necessary.

**Note:** When checking operation, the mechanism must be attached to the cover

3. Check the (2) springs and pins. If either is defective, remove and replace with new springs and pins.
4. Inspect motive pressure inlet and vent valves. Blow out valves using compressed air and clean the valve and seats. Replace if necessary. If the

motive pressure valve is leaking, the inlet valve may be obstructed or damaged. Replace the inlet valve and seat assembly, if necessary. This can be done by unbolting the cover from the mechanism at the underside of the cover. When replacing motive pressure inlet and vent valves use Teflon thread sealant sparingly and make sure to not over torque.

5. Make sure the pump mechanism is in the proper orientation when reassembling. Proper orientation can be seen below in Figure 9. Pump mechanism must be inserted perpendicular to check valve direction. Make sure cover gasket is installed along with the pump cover. A replacement gasket may be necessary when reassembling the pump. Cover bolts should be torqued to 32 ft-lbs. Reconnect the motive and vent lines to the pump, refer to the installation instructions section for reference. After the pump is reinstalled, follow the start-up procedures to bring the pump into operation.

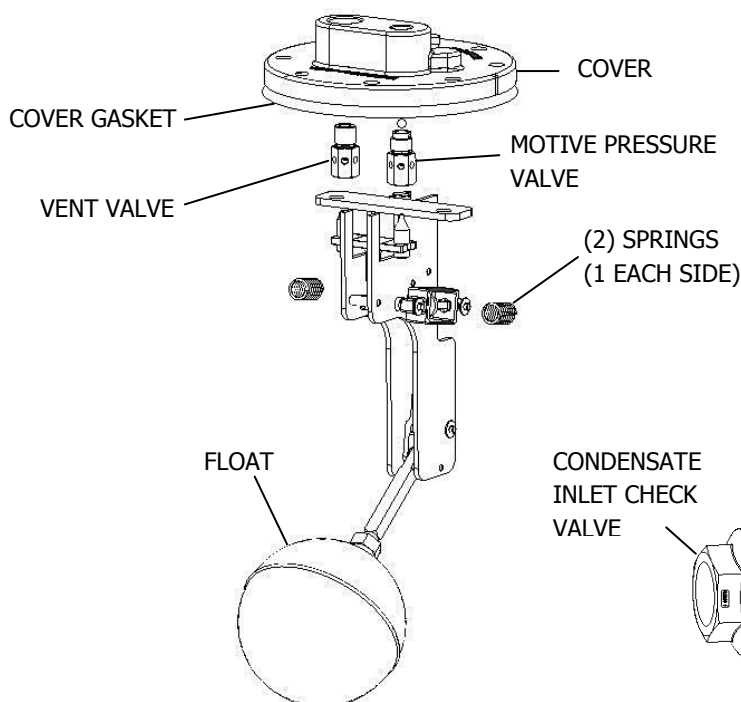

**Figure 8: PMP Internal Mechanism**

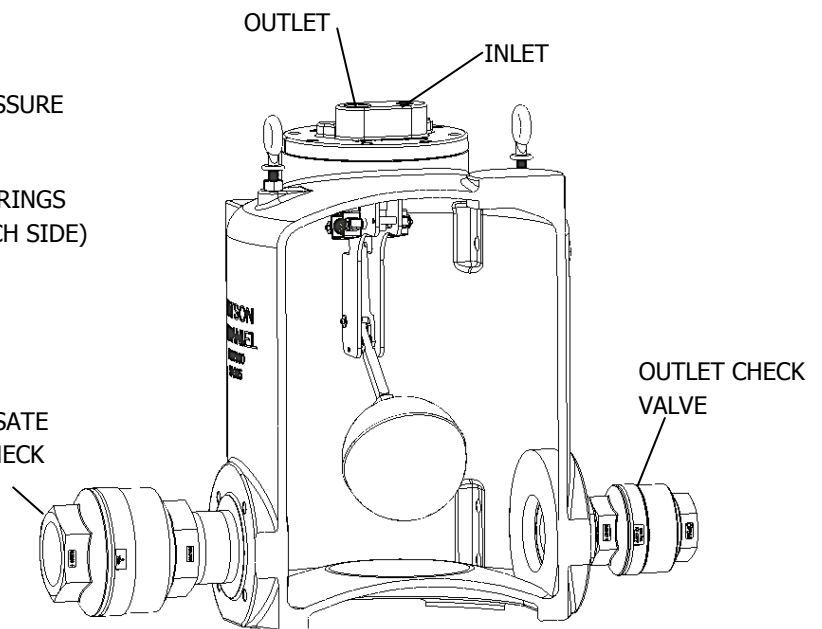

**Figure 9: PMPC Cutaway View**

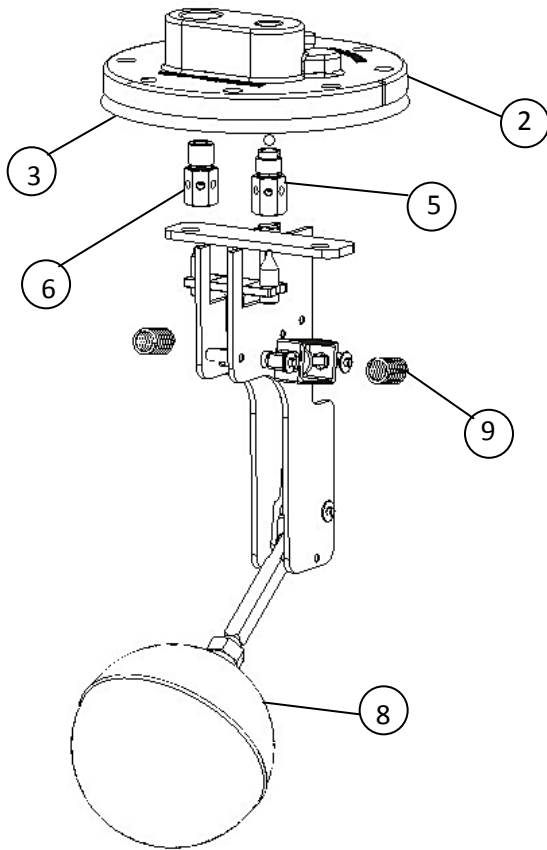

Figure 10: PMP Internal Mechanism

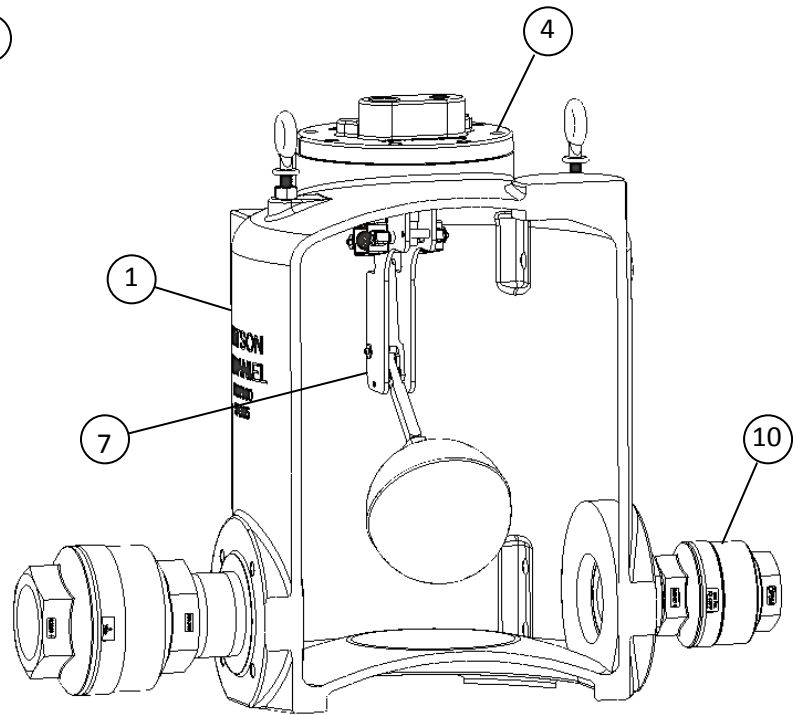

Figure 11: PMPC Cutaway View

PMP Assembly Materials			
ITEM	DESCRIPTION	MODEL	MATERIAL
1	BODY	PMPC	DUCTILE IRON
		PMPSS	304L SST
		PMPLS, PMPF	CARBON STEEL
2	COVER	PMPC	DUCTILE IRON
		PMPSS	304L SST
		PMPLS, PMPF	CARBON STEEL
3	COVER GASKET	ALL	NON ASBESTOS
4	COVER BOLTS	ALL	STEEL
5	INLET VALVE	ALL	17-4 PH S.ST.
6	VENT VALVE	ALL	17-4 PH S.ST.
7	MECHANISM	ALL	304 S.ST.
8	BALL FLOAT	ALL	304 S.ST.
9	SPRINGS	ALL	INCONEL
10	CHECK VALVES	ALL	S.ST.
11	OTHER INTERNAL COMP.	ALL	S.ST.

New Assemblies & Parts for Pressure Motive Pumps		
Model	Kit Order #	Description
PMPF, PMPC, PMPLS, PMPSS All Sizes	W-KIT-900-03	New Mechanism assembly for PMPF
	W-KIT-910-03	New Mechanism assembly for PMPC & PMPLS
	W-KIT-920-03	New Mechanism assembly for PMPSS
	W-KIT-900-04	Cover gasket for PMPF, PMPC, PMPLS & PMPSS
	W-KIT-900-05	Inlet & vent valve assembly for PMPF, PMPC, PMPLS & PMPSS
	W-KIT-900-06	Float and cover gasket for PMPF, PMPC, PMPLS & PMPSS
	W-KIT-900-08	Spring assembly for PMPF, PMPC, PMPLS & PMPSS

Notes: For purchasing stainless steel check valves ½” – 3” NPT – See check valve model WSSCV, in Pipeline Accessories section of the product catalog.

## System Troubleshooting

PROBLEM	POSSIBLE	CAUSE CORRECTION
1. Pump fails to operate on startup.	a) Motive pressure line closed	a) Open valves to supply motive pressure to pump
	b) Motive pressure insufficient to overcome backpressure	b) Check motive pressure and backpressure. Adjust motive pressure to 10 psi (min.) higher than the backpressure
	c) Liquid inlet line closed	c) Open all valves to supply liquid to the pump
	d) Liquid discharge line closed	d) Open all valves on the discharge side of the pump
	e) Pump vapor-locked	e) Break vent connection at pump cover. Stand clear of vent connection. If pump begins to cycle, vapor locking has occurred. Re-check that the exhaust tie-back line is unobstructed and completely self-draining to a lower pressure area with sufficient vapor space
	f) Insufficient fill head to allow pump to trip	f) Check that fill head is large enough for condensate to drain freely by gravity into the pump properly. Raise condensate source or lower pump to achieve required filling head
2. Liquid backup and equipment flooded, but pump appears to cycle normally	a) Motive pressure is too low to achieve required capacity	a) Check motive pressure setting and maximum backpressure during operation. Check against sizing table. Increase motive pressure as required
	b) Insufficient filling head to achieve required capacity	b) Verify required filling head is large enough for condensate to drain freely by gravity into the pump properly. Raise condensate source or lower pump to achieve required filling head
	c) Restriction in liquid inlet line	c) Check that only full ported fittings are used. Clean the strainer. Verify that all valves are fully open
	d) Inlet check valve stuck open	d) Isolate inlet check valve and relieve pressure. Remove cap and visually inspect for debris. Clean seating surfaces and reinstall or replace, if necessary
	e) Pump undersized	e) Verify rated capacity in the sizing capacity table. Increase check valve size or install additional pump as required
3. Liquid backup and equipment flooded, and pump has stopped cycling	a) Motive pressure low	a) If motive pressure is below backpressure, increase motive pressure setting to 10 psi (min.) above backpressure. Do not exceed rated pressure limits of equipment
	b) Discharge line closed via valve blocked with debris	b) Compare motive pressure and backpressure. If backpressure is higher or equal, a closed or blocked discharge line is possible. Check valves downstream of pump

PROBLEM	POSSIBLE	CAUSE CORRECTION
<p>3. (continued) Liquid backup and equipment flooded, and pump has stopped cycling</p> <p><b>SAFETY NOTE TO PREVENT INJURY: For steps (d) through (g), it is necessary to disconnect the vent line at the pump head. It is possible that hot condensate or gas may run out of the vent connection when broken.</b></p>	<p>c) Outlet check valve stuck closed</p> <p>d) Inlet check valve stuck closed</p> <p>e) Motive inlet valve leaking and/or worn</p> <p>f) Mechanism failure 1. Ruptured float 2. Mechanism binding</p> <p>g) Exhaust/tie-back causing vapor lock</p>	<p>c) After checking per step 3(b), isolate discharge check valve and relieve line pressure. Remove cap and visually inspect. Clean seating surfaces and reinstall or replace, if necessary</p> <p>d) If mechanism is not heard to trip and fluid is not running from the vent connection, it is suspected that the fault lies in the condensate inlet piping. Be sure that all valves leading to the pump have been opened. If so, this is a possible indication that the inlet check valve is stuck closed. Isolate the pump and check valve and relieve line pressure. Remove the check valve and visually inspect. Clean seating surfaces and reinstall or replace, if necessary. Reinstall exhaust/tie-back connection and open line</p> <p>e) Gradually open motive supply line, leaving the condensate inlet and discharge lines closed. Observe the vent connection for steam or air leakage. If observed, inlet valve is obstructed or damaged. With pump isolated, remove cover and visually inspect. Replace inlet valve and seat assembly</p> <p>f) Keeping motive line open, slowly open condensate inlet line to the pump, allowing pump to fill and observe vent connection. If condensate runs out of vent connection, a mechanism problem is apparent. Isolate pump by shutting off motive supply and condensate inlet, remove cover and visually inspect. Examine float for defects. Stroke mechanism and check for any binding or increased friction. Repair or replace as needed</p> <p>g) Recheck the vent/tie-back piping layout for compliance with the installation instructions. Check that the exhaust tie-back line is unobstructed and completely self-draining to a lower pressure area with sufficient vapor space</p>
<p>4. Valve will not close</p>	<p>a) When a pump discharges a significant volume of liquid into a long horizontal return line with rises and drops, the sudden changes in velocity can develop a vacuum</p> <p>b) Pump is blowing by</p>	<p>a) Install a vacuum breaker at high point in return line. For pressurized return systems, an air eliminator may be required downstream of the vacuum breaker</p> <p>b) Compare inlet and outlet pump pressure. If the inlet pressure equals or exceeds the backpressure, a "blow through" problem is possible</p>